

Наименование на материала:

**Триполюсни автоматични прекъсвачи НН с
лят корпус, от 160 А до 1250 А, с електронна
защита, категория А**

№ по ред	Документ	Приложение № или текст
1.	Точно означение на типа, производителя и страната на производство (произход) и последно издание на каталога на производителя	Susol, LS Industrial Systems, Южна Корея, TS 1250H Приложение 1
2.	Техническо описание и чертежи с нанесени на тях размери	Приложение 2
3.	ЕО декларация за съответствие	Приложение 3
4.	Протоколи от типови изпитвания на английски или български език, проведени от независима изпитвателна лаборатория – заверени копия, с приложен списък на отделните изпитвания на български език	Приложение 4
5.	Сертификат/акредитация на независимата изпитвателна лаборатория, провела типовите изпитвания по т. 4 – заверено копие	Приложение 5
6.	Инструкции за транспортиране, складиране, монтиране, вкл. въртящия момент на затягане на клемовите съединения, обслужване и поддържане	Приложение 6

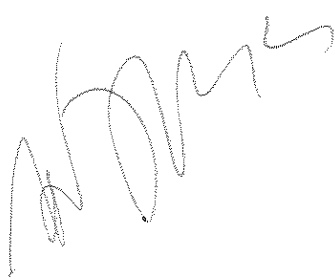

на основание чл. 2 от ЗЗЛД

/Антон Илнев/

Switch-Disconnectors

Susol

TD series

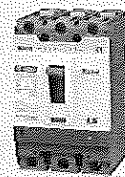
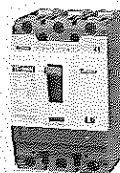

Frame size		[AF]
Conventional thermal current, Ith		[A]
No. of poles		
Rated operational voltage, Ue	AC	[V]
	DC	[V]
Rated operational current, Ie		
Rated impulse withstand voltage, Uimp		[kV]
Rated insulation voltage, Ui		[V]
Rated short-circuit making capacity, Icm		[kA peak]
Rated short-time withstand current, Icw	1s	[A rms]
	3s	[A rms]
	20s	[A rms]
Isolation behavior		
Trip unit (release)		
	● disconnecter unit	DSU
Connection	fixed	front-connection
		rear-connection
	plug-in	front-connection
		rear-connection
Mechanical life		[operations]
Electrical life @415 V AC		[operations]
Basic dimensions, W×H×D (front connection)	3-pole	[mm]
	4-pole	[mm]
Weight (front connection)	3-pole	[kg]
	4-pole	[kg]
Reference standard		

TD160NA	TS100NA	TS160NA
160	100	160
160	100	160
2, 3, 4	2, 3, 4	2, 3, 4
690	690	690
500	500	500
160	100	160
8	8	8
750	750	750
3.1	2.8	3.6
2200	2000	2500
2200	2000	2500
960	690	960
●	●	●
●	●	●
●	●	●
●	●	●
●	●	●
●	●	●
25000	25000	25000
10000	10000	10000
90×140 86	105×160×86	105 160×86
120 140×86	140×160×86	140 160×86
1.5	2	2
1.8	2.6	2.6
IEC60947-3	IEC60947-3	IEC60947-3

The switch-disconnectors are different from the circuit-breakers in the absence of the conventional protection unit. They keep the overall dimensions, connection systems and accessories unchanged from the corresponding circuit-breakers. Installation standards require upstream protection. However, thanks to their high-set magnetic release, TD160 ... TS800 DSU are self protected.

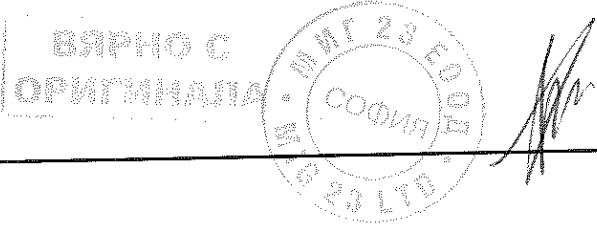

Switch-Disconnectors

Susol

TS series

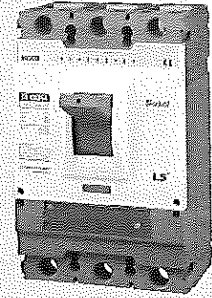
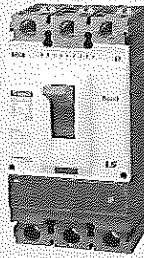
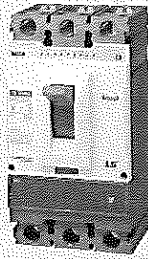

TS250NA

TS400NA

TS630NA

TS800NA

250

400

630

800

250

400

630

800

2, 3, 4

2, 3, 4

2, 3, 4

2, 3, 4

690

690

690

690

500

500

500

500

250

400

630

800

8

8

8

8

750

750

750

750

4.9

7.1

8.5

12

3500

5000

6300

8000

3500

5000

6300

8000

1350

1930

2320

2560

●

●

●

●

●

●

●

●

●

●

●

●

●

●

●

●

25000

20000

20000

10000

10000

6000

6000

3000

105 160 86

140 × 260 × 110

140 260 110

210 320 135

140 160 86

186.5 260 110

186.5 260 × 110

280 320 135

2

5.4

5.4

15.1

2.6

7.2

7.2

19.6

IEC60947-3

IEC60947-3

IEC60947-3

IEC60947-3

Trip unit identification

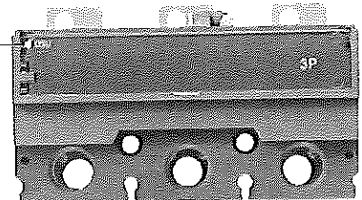

ВАРНО С
ОРИГИНАЛА

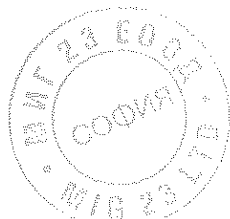

[Handwritten signature]

MCCBs for power distribution

Susol

Electrical characteristics

		TE100	TE160	TD100	TD160						
Frame size	[AF]	100	160	100	160						
Rated current, In *	[A]	16-100	100,125,160	16, 20, 25, 32, 40, 50, 63, 80, 100	1P: 16, 20, 25, 32, 40, 50, 63, 80, 100,125, 160						
No. of poles		3,4	3,4	2*, 3, 4	1, 2*, 3, 4						
Rated operational voltage, Ue	AC	690	690	690	240(1P), 690						
	DC	500	500	500	250(1P), 500						
Rated impulse withstand voltage, Uimp	[kV]	8		8	8						
Rated insulation voltage, Ui	[V]	8		750	750						
Rated ultimate short-circuit breaking capacity, Icu	AC 50/60Hz	S	N	S	N	N	H	L	N	H	L
	DC	S	N	S	N	N	H	L	N	H	L
Rated service breaking capacity, Ics [%Icu]	AC 50/60Hz	50	85	50	85	85	100	200	30(1P) 85	50(1P) 100	200
	380/415V	37	50	37	50	50	85	150	50	85	150
	440/460V	25	37	25	37	50	70	130	50	70	130
	480/500V	18	25	18	25	30	50	65	30	50	65
	660/690V	6	8	6	8	5	8	10	5	8	10
DC	250V	37	50	37	50	42	65	100	16(1P) 42	25(1P) 65	100
500V(2poles in series)	37	50	37	50	42	65	100	42	65	100	
Rated short-circuit making capacity Icm	AC 50/60Hz	105	187	105	187	187	220	440	105(1P) 187	105(1P) 220	440
380/415V	77.7	105	77.7	105	105	187	330	105	187	330	
440/460V	52.5	77.7	52.5	77.7	105	154	286	105	154	286	
480/500V	36	52.5	36	52.5	63	105	143	63	105	143	
660/690V	9.2	13.6	9.2	13.6	8	14	17	8	14	17	
Category of utilization		A	A	A	A	A	A	A	A	A	
Isolation behavior		●	●	●	●	●	●	●	●	●	
Trip unit (release)	Thermal-Magnetic										
	Electronic										
Option	Earth-fault protection, Ig	●	●	●	●	●	●	●	●	●	
	Zone selective interlocking, ZSI	●	●	●	●	●	●	●	●	●	
Ammeter	-	-	-	-	-	-	-	-	-	-	
Communication	-	-	-	-	-	-	-	-	-	-	
Earth-leakage protection module ****	-	-	-	-	-	-	-	-	-	-	
Connection	fixed	●	●	●	●	●	●	●	●	●	
	plug-in	●	●	●	●	●	●	●	●	●	
Mechanical life	[operations]	25000	25000	25000	25000	25000	25000	25000	25000	25000	
Electrical life @ 415 V AC	[operations]	10000	10000	10000	10000	10000	10000	10000	10000	10000	
Basic dimensions, W×H×D (front connection)	1-pole	-	-	-	-	-	-	-	35	140	86
	3-pole	76	130	82	76	130×82	90	140	86	90	140
	4-pole	101	130	82	101	130	82	120	140	86	120
Weight (front connection)	1-pole	-	-	-	-	-	-	-	0.57	-	-
	3-pole	1.05	1.05	1.05	1.05	1.05	1.5	1.5	1.5	1.5	1.5
	4-pole	1.35	1.35	1.35	1.35	1.35	1.8	1.8	1.8	1.8	1.8
Reference standard		IEC60947-2	IEC60947-2	IEC60947-2	IEC60947-2	IEC60947-2	IEC60947-2	IEC60947-2	IEC60947-2	IEC60947-2	IEC60947-2

* Applicable to MCCBs equipped with FTU, FMU, ATU
 ** 2 pole MCCB in 3pole frame size
 *** Available for 3pole circuit breakers
 **** Under development
 ***** Not applicable to 1pole
 *** 700A only available for 3800FTU

A-2-1

MCCBs for power distribution up to 1600A

Susol

Electrical characteristics

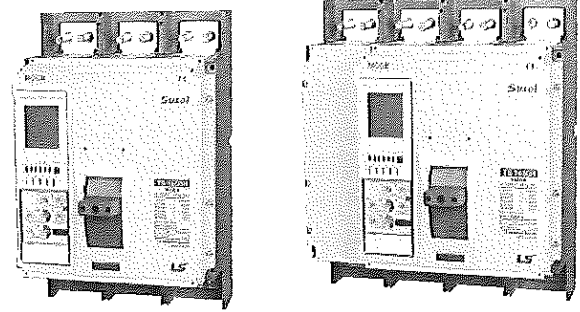

Type			
Ampere frame			
Pole			
Rated current, (A)	In	-5~40°C	
		50°C	
		65°C	
Rated insulation voltage, (V)		Ui	
Rated impulse withstand voltage, (kV)		Uimp	
Rated operational voltage, (V)		Ue AC50/60Hz	
		DC	
Rated short-circuit breaking capacity			
IEC60947-2 AC50/60Hz (sym)	Rated ultimate short-circuit breaking capacity, (kA) (Icu)	220/240V	
		380/415V	
		440/460V	
		480/500V	
		660/690V	
	DC	250V 2P	
		500V 2P	
		750V 3P	
Rated service breaking capacity (Ics)		%Icu	
Rated short-circuit making capacity (kA) (Icw)	AC50/60Hz	1s	
		3s	
Overriding instantaneous protection		kA peak	
Isolation			
Category			
(Life cycle)	Mechanical life (operations)		
	Electrical life (operations)	440V	In/2
		690V	In/2
			In
Pollution degree			
Dimension (mm)		3-pole	
(H W D)		4-pole	
Weight (kg)		3-pole	
		4-pole	

TS1000			TS1250			TS1600		
TS1000			TS1250			TS1600		
1000			1250			1600		
3, 4			3, 4			3, 4		
800, 1000			1250			1600		
800, 1000			1250			1560		
800, 1000			1240			1420		
1000			1000			1000		
8			8			8		
690			690			690		
-			-			-		
N	H	L	N	H	N	H		
55	75	200	55	75	55	75		
50	70	150	50	70	50	70		
50	65	130	50	65	50	65		
40	50	100	40	50	40	50		
35	45	50	35	45	35	45		
-	-	-	-	-	-	-		
-	-	-	-	-	-	-		
-	-	-	-	-	-	-		
100%	75%	100%	100%	75%	100%	75%		
25		12	25		25			
-		-	-		-			
50		30	50		50			
O		O	O		O			
B		A	B		B			
10000		4000	10000		10000			
6000		4000	5000		5000			
5000		3000	4000		2000			
4000		3000	3000		2000			
2000		2000	2000		1000			
3			3		3			
			327×210×152.5					
			327 280 152.5					
			13					
			16.8					

A-2-65

ВЯРНО
ОРИГИНАЛ

ТЕХНИЧЕСКО ОПИСАНИЕ

I. Триполюсни автоматични прекъсвачи серия Susol за ток от 1250 до 1600А,

Автоматични прекъсвачи серия Susol TS са произведени от фирма LS Industrial Systems и представляват механични комутационни апарати, способни да провеждат и да включват/изключват ръчно електрически токове до 1600 А във вериги при нормални условия и да провеждат за определено време и да изключват автоматично токове във вериги при условията на претоварване и късо съединение.

Тялото на автоматични прекъсвачи е изработено чрез формоване на устойчив на нагряване, на огън и на механични удари изолационен материал. В монтирано състояние съгласно инструкциите на производителя и след опроводяване активните части на миниатюрните автоматични прекъсвачи не са достъпни.

При вертикално монтиране на автоматични и товарови прекъсвачи лостът се движи в направление „нагоре - надолу“, при което контактите се затварят при движение „нагоре“. Автоматични прекъсвачи са снабдени с ясно видимо от челната страна средство за указване на затвореното и отвореното положение на контактната система- Означение „ON/OFF“ върху лоста за управление. При задействане на защитата (или натискане на специален бутон на лицевата страна) лоста застава в „Trip“ положение, което е оказано със символ на челната страна. За да се включи прекъсвача от „Trip“ положение лостът първо трябва да се придвижи надолу към положение „OFF“, а след това нагоре до положение „ON“. Устройствата отговарят на следните стандарти: EN/IEC 60947-1, EN/IEC 60947-2, EN/IEC 60947-3, EN/IEC 60947-4.

Прекъсвачите са маркирани с СЕ маркировка за съответствие и на лицевия панел на устройството са отпечатани следните основни параметри:

- Разривен ток при различни напрежения
- Допустимо импулсно напрежение на излолацията
- Номинален ток
- Номинално напрежение
- Краткотрайно издържан ток
- Работна изключвателна възможност

Автоматични и товарови прекъсвачи серия Susol са снабдени с ротационна контактна система и имат повишена изключвателна възможност поради двойното разкъсване всеки полюс.

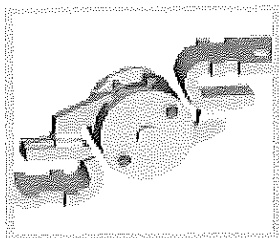

Ротационната контактна система има следните преимущества:

- Двойно разкъсване на всеки полюс
- Мигновено отвеждане на дъгата към дъгогасителните камери
- Повишава дълготрайността на контактите като ги предпазва от износване
- Отлични токоограничаващи свойства
- Висока изключвателна възможност при компактни размери

ВЯРНО С
ОРИГИНАЛА

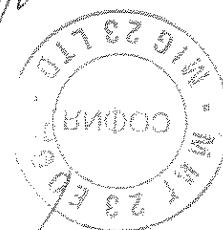

TS 1000, 1250, 1600A

Front Type

[Handwritten signature]

[mm]

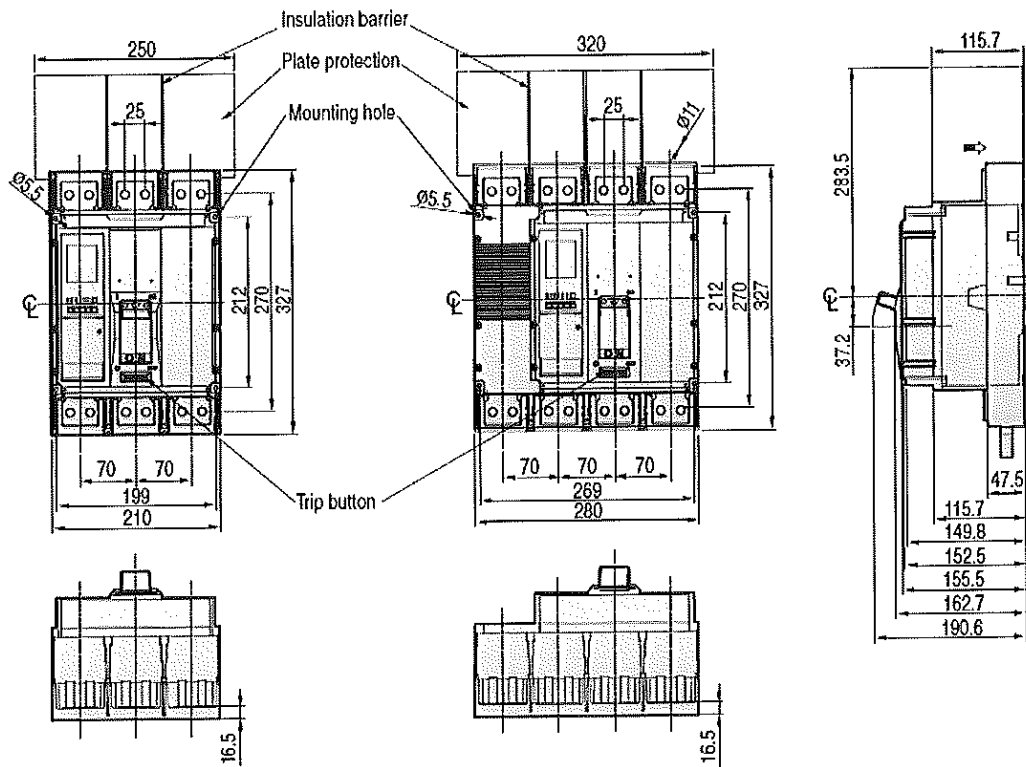

ВЯРНО С
ОРИГИНАЛА

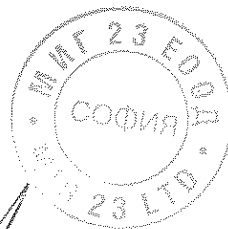

[Handwritten signatures]

ДЕКЛАРАЦИЯ ЗА СЪОТВЕТСТВИЕ

Долуподписаният Владимир Лазаров,

Управител на фирма "ВиВ Изоматик" ООД, София, ул. Пирин 40А

В качеството си на търговски представители на LS Industrial Systems Co., Ltd.

Декларираме, че продуктът:

Марка: LS Industrial Systems
Продукт: Автоматичен прекъсвач
TS1000N, TS1250N, TS1600N
TS1000H, TS1250H, TS1600H
TS1000L, TS1250L, TS1600L
TS1000NA, TS1250NA, TS1600NA

Серия: SuSol

За който се отнася тази декларация, при условие, че е инсталиран, обслужван и използван за приложения, за които е предназначен, е в съответствие със следните стандарти, технически одобрения или други нормативни актове:

IEC 60947-1
IEC 60947-2



на основание чл. 2 от ЗЗЛД

София, 18.01.2012

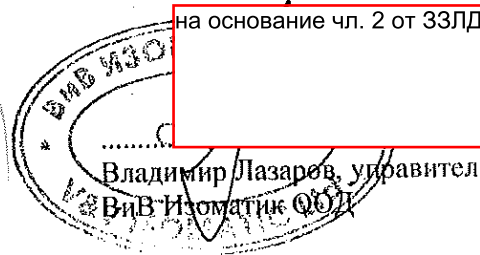

Владимир Лазаров, управител
"ВиВ Изоматик" ООД



CB TEST CERTIFICATE

Ref. Certificate No.

NL-20335

IEC SYSTEM FOR MUTUAL RECOGNITION OF TEST CERTIFICATES FOR ELECTRICAL EQUIPMENT (IECEE) CB SCHEME

Issued by: DEKRA Certification B.V.

Product: Moulded-case circuit-breaker

Applicant: LS Industrial Systems Co., Ltd. 1026-6, Hogye-dong, Dong-an-gu Anyang-si, Gyeonggi-do Korea, Republic of

Manufacturer: LS Industrial Systems Co., Ltd. 1026-6, Hogye-dong, Dong-an-gu Anyang-si, Gyeonggi-do Korea, Republic of

Factory: LS Industrial Systems Co., Ltd. 1026-6, Hogye-dong, Dong-an-gu Anyang-si, Gyeonggi-do Korea, Republic of

Rating and principal characteristics: 3P/3P+N MCCB (electronic); Ue = 220/240, 380/415, 440/460, 480/500, 660/690 V; Ie = 630, 800, 1000, 1250, 1600 A; Uimp = 8 kV; Ui = 1000 V; TS1000H, TS1250H, TS1600H: Icu = 75 kA at 220/240 V, 70 kA at 380/415 V, 65 kA at 440/460 V, 50 kA at 480/500 V, 45 kA at 660/690 V; Ics = 75% of Icu; Icw = 25 kA – 1 s; TS1000N, TS1250N, TS1600N: Icu = 55 kA at 220/240 V, 50 kA at 380/415 V, 50 kA at 440/460 V, 40 kA at 480/500 V, 35 kA at 660/690 V; Ics = 100% of Icu; Icw = 25 kA – 1 s; IP30; 50/60 Hz; Utilization category B;

Trade mark (if any): LS

Type of Manufacturer's Testing Laboratories used: WMT

Model/Type reference: TS1000N, TS1250N, TS1600N, TS1000H, TS1250H, TS1600H

Additional information: -

Sample of product tested to be in conformity with IEC: 60947-2(ed.4);am1

Test Report Ref. No: 2131728.51

This CB Test Certificate is issued by the National Certification Body:

DEKRA Certification B.V.
Utrechtseweg 310
P.O. Box 5185
6802 ED Arnhem
The Netherlands

на основании чл. 2 от 33ЛД

Signed by: H.R.M. Ba

Date of issue: 2011-04-19



DEKRA Certification is former KEMA Quality

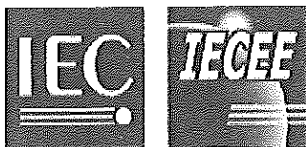

Test Report issued under the responsibility of:



[Handwritten signature]

TEST REPORT IEC 60947-2 Low-voltage switchgear and controlgear - Part 2: Circuit-breakers	
Report Reference No.....	2131728.51
Date of issue.....	2011-04-19
Total number of pages	133
CB Testing Laboratory.....	DEKRA Certification B.V.
Address	Utrechtseweg 310, 6812 ARNHEM, The Netherlands
Applicant's name.....	LS Industrial Systems Co., Ltd.
Address	1026-6, Hogye-dong, Dong-an-gu Anyang-si, Gyeonggi-do, Korea
Test specification:	
Standard.....	IEC 60947-2:2006 (4 th Edition) + amendment 1: 2009
Test procedure	CB
Non-standard test method.....	N/A
Test Report Form No.....	IEC60947_2F
Test Report Form(s) Originator	KEMA Quality BV
Master TRF	Dated 2010-01
Copyright © 2010 IEC System for Conformity Testing and Certification of Electrical Equipment (IECEE), Geneva, Switzerland. All rights reserved.	
This publication may be reproduced in whole or in part for non-commercial purposes as long as the IECEE is acknowledged as copyright owner and source of the material. IECEE takes no responsibility for and will not assume liability for damages resulting from the reader's interpretation of the reproduced material due to its placement and context.	
If this Test Report Form is used by non-IECEE members, the IECEE/IEC logo and the reference to the CB Scheme procedure shall be removed.	
This report is not valid as a CB Test Report unless signed by an approved CB Testing Laboratory and appended to a CB Test Certificate issued by an NCB in accordance with IECEE 02.	
Test item description	Moulded-case circuit-breaker
Trade Mark	LS
Manufacturer	LS Industrial Systems Co., Ltd.
Model/Type reference.....	TS1000N, TS1250N, TS1600N, TS1000H, TS1250H, TS1600H
Ratings	630, 800, 1000, 1250, 1600 A

[Handwritten signature]

ВАРНО С
ОРИГИНАЛА

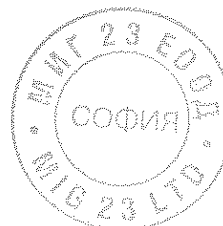

[Handwritten signature]

Testing procedure and testing location:

CB Testing Laboratory:
 Testing location/ address.....:

Associated CB Laboratory:
 Testing location/ address.....:
 Tested by (name + signature).....:
 Approved by (+ signature)

Testing procedure: TMP
 Tested by (name + signature).....:
 Approved by (+ signature)

Testing procedure: WMT
 Tested by (name + signature).....: Oh Junsick
 Witnessed by (+ signature).....: F.S.Strikwerda
 Approved by (+ signature)

Testing location/ address.....: LS Industrial Systems, Ltd. Cheongju Plant
 1, Songjeong-dong, Heungdeok-gu Cheongju-si,
 Chungcheongbuk-do, Korea

Testing procedure: SMT
 Tested by (name + signature).....:
 Approved by (+ signature)

Supervised by (+ signature).....:
 Testing location/ address.....:

Testing procedure: RMT
 Tested by (name + signature).....:
 Approved by (+ signature)

Supervised by (+ signature).....:
 Testing location/ address.....:

на основание чл. 2 от ЗЗЛД

[Handwritten signature]

ВЕРНО С
ОРИГИНАЛА

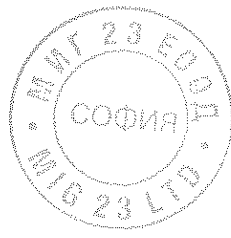

[Handwritten signature]

<p>Summary of testing:</p>											
<p>Tests performed (name of test and test clause):</p> <p>8.3.3 Test sequence I: General performance characteristics</p> <p>8.3.4 Test sequence II: Rated service short-circuit breaking capacity</p> <p>8.3.5 Test sequence III: Rated ultimate short-circuit breaking capacity</p> <p>8.3.6 Test sequence IV: Rated short-time withstand current</p> <p>Annex F : Additional tests for circuit-breakers with electronic over-current protection</p> <p>4pole is covered by tests of Annex F on the TS1600H 3pole because the construction is identical.</p> <p>Annex H: Test sequence for circuit-breakers for IT systems.</p> <p>4pole is covered by tests of Annex H on the TS1600H 3pole because the construction is identical.</p> <p>Ground fault release was not tested because the min. fault current is > 30A</p> <p>H-type covers the N-type because the construction is identical, only difference in marking</p>	<p>Testing location:</p> <p>LS Industrial Systems Co., Ltd. CheongJu Plant</p> <p>1, Songjeong-dong, Heungdeok-gu Cheongju-si, Chungcheongbuk-do, Korea, Republic Of</p>										
<p>Summary of compliance with National Differences: N/A</p>											
<p>Copy of marking plate</p>											
<table border="1"> <tr> <td style="text-align: center;"> </td> <td style="text-align: center;"> </td> <td style="text-align: center;"> </td> <td style="text-align: center;"> </td> <td style="text-align: center;"> </td> </tr> <tr> <td style="text-align: center;"> </td> <td style="text-align: center;"> </td> <td style="text-align: center;"> </td> <td style="text-align: center;"> </td> <td style="text-align: center;"> </td> </tr> </table>											

TRF No. IEC60947_2F

ВЕРНО С
ОРИГИНАЛА

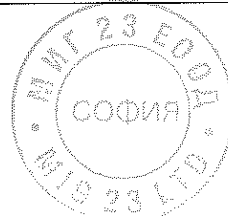

Test item particulars: test item vs. test requirements	
3. Classification	
3.1. Utilization category: (A or B).....	: B
3.2. Interruption medium: (air, vacuum, gas Break)	: Air
3.3. Design: (open construction, moulded case)	: Moulded case
3.4. Method of controlling the operation mechanism: (dependent manual, independent manual, dependent power, independent power).....	: Independent manual
3.5. Suitability for insulation: (suitable, not -suitable).....	: Suitable
3.6. Provision for maintenance: (maintainable, non maintainable)	: Maintainable
3.7. Method of installation: (fixed, plug in, withdrawable:	: Fixed
3.8. Degree of protection: (IP code).....	: IP30
4.7. Type of release (thermo-magnetic / electronic).....	: Electronic
4.8. Integral fuses (integrally fused circuit-breakers) Type and characteristics of SCPD	: N/A
7.3 Electromagnetic compatibility (EMC) Environment A or B	: A
Circuit-breaker for use on phase-earthed systems	: N/A
Circuit-breaker for use in IT systems	: P
Rated and limiting values, main circuit	
- rated operational voltage: U_e (V)	: 220/240, 380/415, 440/460, 480/500, 660/690 V
- rated insulation voltage: U_i (V)	: 1000 V
- rated impulse withstand voltage: U_{imp} (kV)	: 8 kV
- rated operational current: I_e (A)	: 630, 800, 1000, 1250, 1600 A
- kind of current.....	: AC
- conventional free air thermal current: I_{th} (A)	: 1600 A
- conventional enclosed thermal current: I_{the} (A).....	: N/A
- current rating for four-pole circuit-breakers: (A)	: N/A
- number of poles	: 3/4P
- rated frequency: (Hz).....	: 50/60 Hz
- integral fuses (rated values).....	: N/A
Rated duty :	
- eight-hour duty.....	: N/A
- uninterrupted duty: I_u (A).....	: 1600 A

TRF No. IEC60947_2F

ВЕРНО С
ОРИГИНАЛА

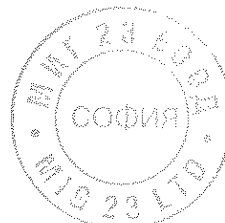

Short-circuit characteristic :	
rated short-time making capacity: I_{cm} (kA)	165 kA
rated ultimate short-circuit breaking capacity: I_{cu} (kA)..	TS1000H, TS1250H, TS1600H 75 kA / 220&240 V, 70 kA / 380&415 V, 65 kA / 440&460 V, 50 kA / 480&500 V , 45 kA / 660&690 V TS1000N, TS1250N, TS1600N 55 kA/220&240 V, 50 kA/380&415 V 50 kA/440&460 V, 40 kA/480&500 V 35 kA/660&690 V
rated service short-circuit breaking capacity: I_{cs} (kA)	$I_{cs} = 75\% I_{cu}$ (H-type), $I_{cs} = 100\% I_{cu}$ (N-type)
rated short-time withstand current: I_{cw} (kA/s)	25 kA 1s
Control circuits :	
Electrical control circuits :	
- kind of current: (AC, DC).....	N/A
- rated frequency: (Hz).....	N/A
- rated control circuit voltage: U_c (nature, frequency, V) ...	N/A
- rated control supply voltage: U_s (nature, frequency V) ...	N/A
Air supply control circuits: (pneumatic or electro-pneumatic) :	N/A
- rated pressure and its limit.....	N/A
- volumes of air, at atmospheric pressure, required for each closing and each opening operation	N/A
Auxiliary circuits :	
Rated and limiting values, auxiliary circuits.....	N/A
- rated operational voltage U_e (V)	N/A
- rated insulation voltage: U_i (V)	N/A
- rated operational current: I_e (A)	N/A
- kind of current.....	N/A
- rated frequency: (Hz).....	N/A
- number of circuits.....	N/A
- number and kind of contact elements	N/A
- rated uninterrupted current: I_u (A).....	N/A
- utilization category: (AC, DC, current and voltage).....	N/A
Short-circuit characteristic :	
- Rated conditional short-circuit current (kA)	N/A
- kind of protective device.....	N/A

TRF No. IEC60947_2F

ВАРНО С
ОРИГИНАЛА

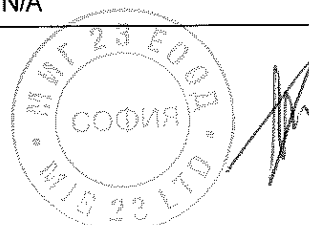

Releases :	
1) shunt release.....	: N/A
2) Over-current release	:
a) instantaneous.....	: P
b) definite time delay	: P
c) inverse time delay.....	: P
- independent of previous load.....	: P
- dependent on previous load; (for example thermal type release).....	: N/A
3) Undervoltage release (for opening).....	: N/A
4) Other releases.....	: N/A
Characteristics :	
1) Shunt release and undervoltage release (for opening) ... :	
- rated control circuit voltage: U_c (nature, frequency, V) ... :	: N/A
- kind of current.....	: N/A
- rated frequency: (if AC).....	: N/A
2) Over-current release	:
- rated current.....	: 630, 800, 1000, 1250, 1600 A
- kind of current.....	: AC
- rated frequency: (if AC).....	: 50/60 Hz
- current setting (or range of settings).....	: 0,4~1,0 I_n
- time settings (or range of settings)	: 50, 100, 200, 300, 400 ms @ 1,5 ~ 10 Ir

ВЯРНО С
ОРИГИНАЛА

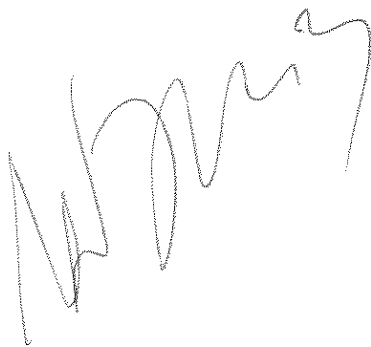
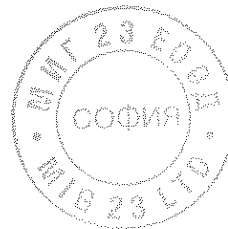

Classification of installation and use	Moulded case circuit breaker
Supply Connection.....	3 phase + N
.....	
.....	
Possible test case verdicts:	
- test case does not apply to the test object.....	N/A
- test object does meet the requirement	P (Pass)
- test object does not meet the requirement	F (Fail)
Testing	
Date of receipt of test item	July 10, 2010
Date (s) of performance of tests	July 12, 2010~ August 30,2010
General remarks:	
The test results presented in this report relate only to the object tested. This report shall not be reproduced, except in full, without the written approval of the Issuing testing laboratory. "(See Enclosure #)" refers to additional information appended to the report. "(See appended table)" refers to a table appended to the report. Throughout this report a comma (point) is used as the decimal separator.	

ВЕРНО С
ОРИГИНАЛА

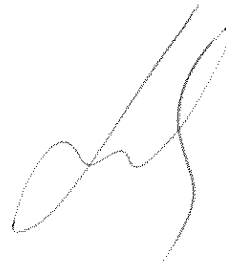
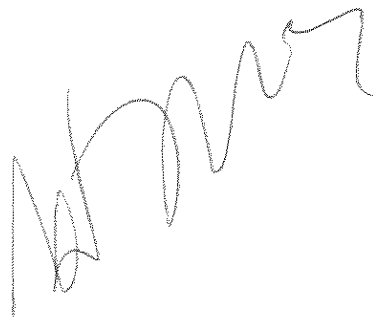
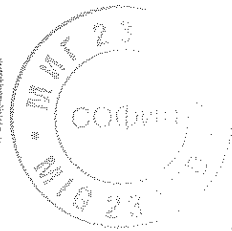



General product information:		
Subject	Molded-case circuit-breaker	
Manufacturer	LS Industrial Systems Co., Ltd.	
Type designation	TS1000N, TS1250N, TS1600N TS1000H, TS1250H, TS1600H	
Frame size	1000, 1250, 1600 AF	
Number of poles	3/4P	
Rated frequency	50/60 Hz	
Rated operational voltage	AC 220/240, 380/415, 440/460, 480/500, 660/690 V	
Rated insulation voltage	AC 1000 V	
Rated impulse withstand voltage	8 kV	
Suitability for isolation	Yes	
Rated current	630, 800, 1000, 1250, 1600A	
Rated ultimate short-circuit breaking capacity	H	N
	75 kA/220&240 V	55 kA/220&240 V
	70 kA/380&415 V	50 kA/380&415 V
	65 kA/440&460 V	50 kA/440&460 V
	50 kA/480&500 V	40 kA/480&500 V
Rated service short-circuit breaking capacity	Ics = 75% Icu	Ics = 100% Icu
Rated short-time withstand current	25 kA 1sec	
Utilization category	B	
Type of tripping device	Electronics Trip Device	
Short time releases:		
Current setting (or range of settings)	1.5-2-3-4-5-6-8-10 I _r (adjustable-8 settings)	
Time setting (or range of setting)	I _t off : 0.05-0.1-0.2-0.3-0.4 (adjustable-5 settings) I _t on : 0.1-0.2-0.3-0.4 (adjustable-4 settings)	
Instantaneous releases:	Electronics Trip Device	
Current setting (or range of settings)	2-3-4-6-8-10-12-15 I _n (adjustable-8 settings)	
Time setting (or range of setting)	Fixed (<50ms)	
Long time release:		
Current setting (or range of settings)	0.4~1.0 I _n (adjustable-54 settings)	
Time setting (or range of setting)	0.5-1-2-4-8-12-16-20 (adjustable-8 settings)	
Type of neutral	Over-current release	
Release dependent on ambient air temperature	No	
Reference temperature	40 °C	
Dimension of specimen	327(H)X210(W)X152.5(D)[3P] / 327(H)X280(W)X152.5(D)[4P]	
Dimension <input type="checkbox"/> metal screen	644(H)X357(W)X152.5(D)[3P] / 644(H)X427(W)X152.5(D)[4P]	

TRF No. IEC60947_2F

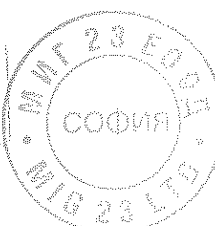
ВЕРНО С
ОРИГИНАЛА

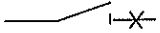

IEC 60947-2			
Clause	Requirement + Test	Result - Remark	Verdict
5.2	MARKING		
a)	The following data shall be marked on the circuit-breaker itself or on a name plate or nameplates attached to the circuit-breaker, and located in a place such that they are visible and legible when the circuit-breaker is installed.		
	- rated current:	630, 800, 1000, 1250, 1600 A	P
	- suitability for isolation, if applicable, with the symbol 	Compliance	P
	- indication of the open and closed position: with \bigcirc and I respectively, if symbols are used	Compliance	P
b)	Marking on equipment not needed to be visible after mounting:		
	- manufacturer's name or trademark	LS	P
	- type designation or serial number	TS1000N, TS1250N, TS1600N TS1000H, TS1250H, TS1600H	P
	- IEC 60947-2 if the manufacturer claims compliance with this standard.	IEC 60947-2	P
	- utilization category	B	P
	- rated operational voltage(s) U_e	220/240, 380/415, 440/460, 480/500, 660/690 V	P
	- Circuit-breaker for use in IT systems: Circuit-breaker for which all values of rated voltage have not been tested according to annex H or are not covered by such testing, shall be identified by the symbol  which shall be marked on the circuit-breaker immediately following these values of rated voltage	Compliance	P
	- value (or range) of the rated frequency and/or the indication DC (or symbol)	50/60 Hz	P
	- rated ultimate short-circuit breaking capacity: I_{cu}	TS1000H, TS1250H, TS1600H 75kA/220&240V, 70kA /380& 415V, 65kA/440&460V, 50kA/480&500V, 45kA / 660&690V TS1000N, TS1250N, TS1600N 55kA/220&240V, 50 kA/380& 415V, 50kA/440&460V, 40 kA/480&500V, 35kA/660&690V	P

TRF No. IEC60947_2F

ВЕРНО С
ОРИГИНАЛА

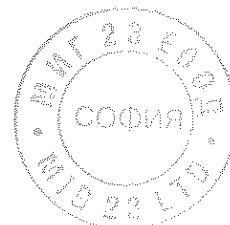

IEC 60947-2			
Clause	Requirement + Test	Result - Remark	Verdict
	- rated service short-circuit breaking capacity, Ics	Ics = 75% Icu (H-type), Ics = 100% Icu (N-type)	P
	- rated short-time withstand current, (Icw) and associated short-time delay, for utilization category B	25 kA 1 s	P
	- line and load terminals, unless their connection is immaterial	Immaterial	P
	- neutral pole terminals, if applicable, by the letter N	-	N/A
	- protective earth terminal, where applicable, by the symbol acc. 7.1.9.3 of part 1	-	N/A
	- ref. temperature for non-compensated thermal releases, if different from 30°C	-	N/A
c)	Marked on the circuit-breaker as specified in item b), or shall be made available in the manufacturer's published information:		
	- rated short-circuit making capacity (Icm) (if higher than specified in 4.3.5.1)	165 kA	P
	- rated insulation voltage. (Ui) if higher than the maximum rated operational voltage)	1000 V	P
	- rated impulse withstand voltage (Uimp), when declared.	8 kV	P
	- pollution degree if other than 3	3	P
	- conventional enclosed thermal current (Ithe) if different from the rated current:	-	N/A
	- IP Code, where applicable:	IP30	P
	- minimum enclosure size and ventilation data (if any) to which marked ratings apply:	-	N/A
	- details of minimum distance between circuit-breaker and earthed metal parts for circuit-breaker intended for use without enclosure:	Compliance	P
	- r.m.s sensing if applicable, according to F.4.1.1	-	N/A
	- suitability for environment A or B	A	P
d)	The following data concerning the opening and closing devices of the circuit-breaker shall be placed either on their own nameplates or on the nameplate of the circuit-breaker:		
	- rated control circuit voltage of the closing device, and rated frequency for AC:	-	N/A

TRF No. IEC60947_2F



IEC 60947-2			
Clause	Requirement + Test	Result - Remark	Verdict
	- rated control circuit voltage of the shunt release and/or of the under-voltage release, and rated frequency:	-	N/A
	- rated current of indirect over-current releases:	-	N/A
	- number and type of auxiliary contacts and kind of current, rated frequency (if AC) and rated voltages of the auxiliary switches, if different from those of the main circuit.	-	N/A
e)	Terminal shall be clearly and permanently identified in acc. with IEC 60445 and annex L:		
	- line terminal	-	N/A
	- load terminal	-	N/A
	- neutral pole terminal "N"	N	P
	- protective earth terminal 	-	N/A
	- terminal of coils (A/B)	-	N/A
	- terminal of shunt release (B)	-	N/A
	- terminals of under-voltage release (D)	-	N/A
	- terminals of interlocking electromagnets (E)	-	N/A
	- terminals of indicated light devices (X)	-	N/A
	- terminals of contact elements for switching devices (no)	-	N/A

7.1	CONSTRUCTION		
7.1.1	Withdrawable circuit-breaker	-	N/A
	In the disconnected position (main- and auxiliary circuits)		
	Isolating distances for circuit-breaker suitable for isolating warranted:	-	N/A
	Mechanism fitted with a reliable indicating device with indicates the position of the isolating contacts.	-	N/A
	Mechanism fitted with interlocks which only permit the isolating contacts to be separate or re-closed when main contacts are open	-	N/A
	Mechanism fitted with interlock, which only permit the main contacts to be closed when the isolating contacts are fully closed.	-	N/A

TRF No. IEC60947_2F

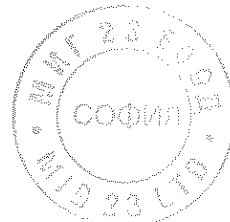
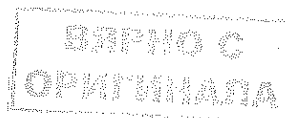

IEC 60947-2			
Clause	Requirement + Test	Result - Remark	Verdict
	Mechanism fitted with interlock, which only permit the main contacts to be closed when in disconnected position.	-	N/A
	The isolating distances between the isolating contacts cannot be inadvertently reduced.	-	N/A
7.1.2.1 part 1	Resistance to abnormal heat and fire	-	N/A
7.1.3 part 1	Current-carrying parts and their connection	Compliance	P
7.1.4	Clearances and creepage distances:		
	For circuit-breakers for which the manufacturer has declared a value of rated impulse withstand voltage. (Uimp.)		
	Clearances distances:		
	- Uimp is given as:	8 kV	
	- max. value of rated operational voltage to earth.....	399 V	
	- nominal voltage of supply system:	690 V	
	- overvoltage category:	IV	
	- pollution degree:	3	
	- field-in or homogeneous:	Inhomogeneous	
	- minimum clearances (mm):	8 mm	
	- measured clearances (mm):	31,3 mm	P
	Creepage distances:		
	- rated insulation voltage Ui (V)	1000V	
	- pollution degree	3	
	- comparative tracking index (V)	175 ≤ CTI < 400	
	- material group	IIIa	
	- minimum creepage distances (mm)	16 mm	
	- measured creepage distances (mm)	32,9 mm	P
7.1.5 part 1	Actuator		
7.1.5.1 part 1	Insulation		
	The actuator of the equipment shall be insulated from the live parts for the rated insulation voltage and, if applicable, the rated impulse withstand voltage	Compliance	P

TRF No. IEC60947_2F

ВЕРНО С
ОРИГИНАЛА

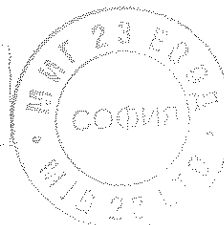

IEC 60947-2			
Clause	Requirement + Test	Result - Remark	Verdict
	If it is made of metal, it shall be capable of being satisfactorily connected to a protective conductor unless it is provided with additional reliable insulation	-	N/A
	If it is made of or covered by insulating material, any internal metal part, which might become accessible in the event of insulation failure, shall also be insulated from live parts for the rated insulation voltage	Compliance	P
7.1.5.2	Direction of movement		
	The direction of operation for actuators of devices shall normally conform to IEC 60447.	Compliance	P
	Where devices cannot conform to these requirements, e.g. due to special applications or alternative mounting positions, they shall be clearly marked such that there is no doubt as to the "I" and "O" positions and the direction of operation	Compliance	P
7.1.6 part 1	Indication of contact position		
7.1.6.1 part 1	Indicating means		
	When an equipment is provided with means for indicating the closed and open positions, these positions shall be unambiguous and clearly indicated	Compliance	P
	This is done by means of a position indicating device (see 2.3.18)	Compliance	P
	If symbols are used, they shall indicate the closed and open position respectively, in accordance with IEC 60417-2:		
	- 60417-2-IEC-5007 I On (power)	Compliance	P
	- 60417-2-IEC-5007 O Off (power)	Compliance	P
	For equipment operated by means of two push-buttons, only the push-button designated for the opening operation shall be red or marked with the symbol "O"	-	N/A
	Red colour shall not be used for any other push-button	-	N/A
	The colours of other push-buttons, illuminated push-buttons and indicator lights shall be in accordance with IEC 60073	-	N/A
7.1.6.2 part 1	Indication by the actuator		

TRF No. IEC60947_2F

ВЕРНО С
ОРИГИНАЛА

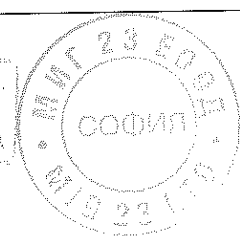

IEC 60947-2			
Clause	Requirement + Test	Result - Remark	Verdict
	When the actuator is used to indicate the position of the contacts, it shall automatically take up or stay, when released, in the position corresponding to that of the moving contacts; in this case, the actuator shall have two distinct rest positions corresponding to those of the moving contacts, but for automatic opening a third distinct position of the actuator may be provided	On position Off position Trip position	P
7.1.7	Additional safety requirements for equipment suitable for isolation		
7.1.7.1	Additional constructional requirements for equipment suitable for isolation (Ue > 50 V):		
	Equipment suitable for isolation shall provide in the open position an isolation distance in acc. with the requirements necessary to satisfy the isolating function. Indication of the main contacts shall be provide by one or more of the following means:		
	- the position of the actuator	Compliance	P
	- a separate mechanical indicator	-	N/A
	- visibility of the moving contacts	-	N/A
	When means are provided or to lock the equipment in the open position, locking only be possible when contacts are in the open position	-	N/A
	Actuator front-plate fitted to the equipment in a manner which ensures correct contact position indication and locking	-	N/A
	The indicated open position is the only position in which the specified isolation distances between the contacts is ensured.	Compliance	P
	- minimum clearances across open contacts (see Table XIII, Part 1) (mm) :	8 mm	
	- measured clearances (mm) :	31,3 mm	P
	- test Uimp across gap (kV) :	12,3 kV	P
7.1.7.2	Supplementary requirements for equipment with provision for electrical interlocking with contactors or circuit-breakers:		
	auxiliary switch shall be rated according to IEC 60 947-5-1	-	N/A
	If equipment suitable for isolation is provided with an auxiliary switch for the purpose of electrical interlocking with contactor (s) or circuit-breaker(s) and intended to be used in motor circuits, the following requirements shall apply unless the equipment is rated for AC-23 utilization category	-	N/A

TRF No. IEC60947_2F

ВЕРНО С
ОРИГИНАЛА

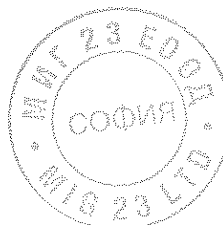

IEC 60947-2			
Clause	Requirement + Test	Result - Remark	Verdict
	The time interval between the opening of the contacts of the auxiliary switch and the contacts of the main poles shall be sufficient to ensure that the associated contactor or circuit-breaker interrupts the current before the main poles of the equipment open	-	N/A
	Unless otherwise stated in the manufacturer's technical literature, the time interval shall be not less than 20 ms when the equipment is operated according to the manufacturer instructions	-	N/A
	Compliance shall be verified by measuring the time interval between the instant of opening of the auxiliary switch and the instant of opening of the main poles under no-load conditions when the equipment is operated according to the manufacturer's instructions	-	N/A
	During the closing operation the contacts of the auxiliary switch shall close after or simultaneously with the contacts of the main poles	-	N/A
	A suitable opening time interval may also be provided by an intermediate position (between the ON and OFF position) at which the interlocking contact(s) is (are) open and the main poles remain closed	-	N/A
7.1.7.3	Supplementary requirements for equipment provided with means for padlocking the open position:		
	the locking means shall be designed in such a way that it cannot be removed with the appropriate padlock(s) installed	-	N/A
	Alternatively, the design may provide padlockable means to prevent access to the actuator	-	N/A
	test force F applied to the actuator in an attempt to operate to the closed position (N) :	-	N/A
	rated impulse withstand voltage (kV) :	-	N/A
	test Uimp on open main contacts at the test force	-	N/A
7.1.8	Terminals		
7.1.8.1	All parts of terminals which maintain contact and carry current shall be of metal having adequate mechanical strength	Compliance	P

TRF No. IEC60947_2F

ВАРНО С
ОРИГИНАЛА

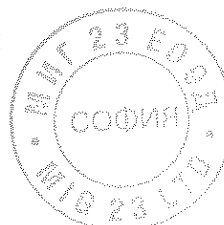

IEC 60947-2			
Clause	Requirement + Test	Result - Remark	Verdict
	Terminal connections shall be such that necessary contact pressure is maintained	Compliance	P
	Terminals shall be so constructed that the conductor is clamped between suitable surfaces without damage to the conductor and terminal	Compliance	P
	Terminal shall not allow the conductor to be displaced or to be displaced themselves in a manner detrimental to the operator of equipment and the insulation voltage shall not be reduced below the rated value	Compliance	P
7.1.8.2	Connection capacity		
	type of conductors :	Flexible and stranded type/ Copper bars	P
	minimum cross-sectional area of conductor (mm ²) :	400 mm ² or 2x(40 mm x 5 mm)	P
	maximum cross-sectional area of conductor (mm ²) :	1000 mm ² or 2x(50 mmx10 mm)	P
	number of conductors simultaneously connectable to the terminal :	2	P
7.1.8.3	Connection		
	terminals for connection to external conductors shall be readily accessible during installation	Compliance	P
	clamping screws and nuts shall not serve to fix any other component	Compliance	P
7.1.8.4	Terminal identification and marking		
	terminal intended exclusively for the neutral conductor	N	P
	protective earth terminal	-	N/A
	other terminals	-	N/A
7.1.9 part 1	Additional requirements for equipment provided with a neutral pole		
	When equipment is provided with a pole intended only for connecting the neutral, this pole shall be clearly identified to that effect by the letter N (see 7.1.7.4).	-	N/A
	A switched neutral pole shall break not before and shall make not after the other poles	-	N/A

TRF No. IEC60947_2F

ВЕРНО С
ОРИГИНАЛА

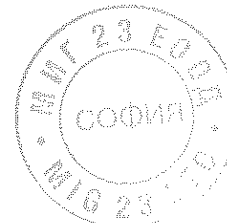

IEC 60947-2			
Clause	Requirement + Test	Result - Remark	Verdict
	For equipment having a value of conventional thermal current (free air or enclosed, see 4.3.2.1 and 4.3.2.2) not exceeding 63 A, this value shall be identical for all poles	-	N/A
	For higher conventional thermal current values, the neutral pole may have a value of conventional thermal current different from that of the other poles, but not less than half that value or 63 A, whichever is the higher	-	N/A
	if a pole with an appropriate making and breaking capacity is used as a neutral pole, then all poles, incl. the neutral pole, shall operate substantially together.	-	N/A
7.1.10	Provisions for protective earthing		
7.1.10.1	The exposed conductive parts (e.g. chassis, framework and fixed parts of metal enclosures) other than those which cannot constitute a danger shall be electrically interconnected and connected to a protective earth terminal for connection to an earth electrode or to an external protective conductor	-	N/A
part 1	This requirement can be met by the normal structural parts providing adequate electrical continuity and applies whether the equipment is used on its own or incorporated in an assembly	-	N/A
	Exposed conductive parts are considered not to constitute a danger if they cannot be touched on large areas or grasped with the hand or if they are of small size (approximately 50 mm x 50 mm) or are so located as to exclude any contact with live parts	-	N/A
7.1.10.2 part 1	Protective earth terminal		
	The protective earth terminal shall be readily accessible and so placed that the connection of the equipment to the earth electrode or to the protective conductor is maintained when the cover or any other removable part is removed	-	N/A
	The protective earth terminal shall be suitably protected against corrosion	-	N/A
	In the case of equipment with conductive structures, enclosures, etc., means shall be provided, if necessary, to ensure electrical continuity between the exposed conductive parts the equipment and the metal sheathing of connecting conductors	-	N/A

TRF No. IEC60947_2F

ВЯРНО С
ОРИГИНАЛА

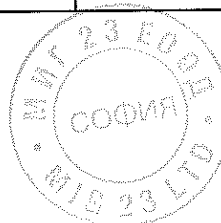

IEC 60947-2			
Clause	Requirement + Test	Result - Remark	Verdict
	The protective earth terminal shall have no other function, except when it is intended to be connected to a PEN conductor (see 2.1.1.5 – Note). In this case, it shall also have the function of a neutral terminal in addition to meeting the requirements applicable to the protective earth terminal	-	N/A
7.1.10.3	Protective earth terminal marking and identification	-	
	The protective earth terminal shall be clearly and permanently identified by its marking	-	N/A
	The identification shall be achieved by colour (green-yellow mark) or by the notation PE, or PEN, as applicable, in accordance with IEC 60445, subclause 5.3, or, in the case of PEN, by a graphical symbol for use on equipment	-	N/A
	Graphical symbol to be used: 60417-2-IEC-5019  Protective earth (ground) in accordance with IEC 60417-2	-	N/A
7.1.11	Enclosure for equipment		
7.1.11.1	Design		
	The enclosure, when it is opened: all parts requiring access for installation and maintenance are readily accessible	-	N/A
	Sufficient space shall be provided inside the enclosure	-	N/A
	The fixed parts of a metal enclosure shall be electrically connected to the other exposed conductive parts of the equipment and connected to a terminal which enables them to be earthed or connected to a protective conductor	-	N/A
	Under no circumstances shall a removable metal part of the enclosure be insulated from the part carrying the earth terminal when the removable part is in place	-	N/A
	The removable parts of the enclosure shall be firmly secured to the fixed parts by a device such that they cannot be accidentally loosened or detached owing to the effects of operation of the equipment or vibrations	-	N/A

TRF No. IEC60947_2F

ВЕРНО С
ОРИГИНАЛА

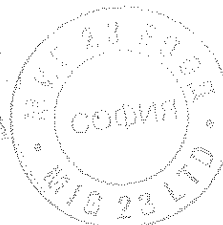

IEC 60947-2			
Clause	Requirement + Test	Result - Remark	Verdict
	When an enclosure is so designed as to allow the covers to be opened without the use of tools, means shall be provided to prevent loss of the fastening devices	-	N/A
	If the enclosure is used for mounting push-buttons, it shall not be possible to remove the buttons from the outside of the enclosure	-	N/A
7.1.11.2	Insulation		
	If, in order to prevent accidental contact between a metallic enclosure and live parts, the enclosure is partly or completely lined with insulating material, then this lining shall be securely fixed to the enclosure	-	N/A
7.1.12	Degree of protection of enclosed equipment		
	Degree of protection.	IP30	
	Test for first characteristic.	IP3X	
	Test for first numeral	1 2 3: Compliance 4 5 6	P
	Test for second characteristic	IPX0	
	Test for second numeral	1 2 3 4 5 6 7 8	P
7.1.13 part 1	Conduit pull-out, torque and bending with metallic conduits		
	Polymeric enclosures of equipment, whether integral or not, provided with threaded conduit entries, intended for the connection of extra heavy duty, rigid threaded metal conduits complying with IEC 60981, shall withstand the stresses occurring during its installation such as pull-out, torque, bending	-	N/A

TRF No. IEC60947_2F

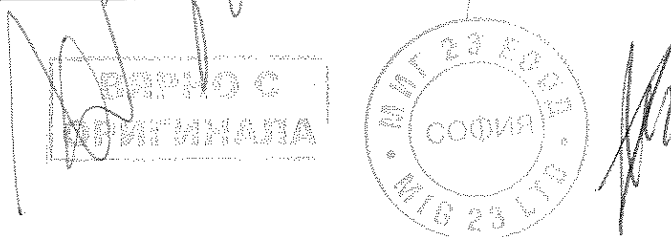

Official stamps and signatures are present at the bottom of the page, including a rectangular stamp with Cyrillic text and a circular stamp with 'M.M.T. 23 E.O.P.A.' and 'MIG 23 LTD'.

IEC 60947-2			
Clause	Requirement + Test	Result - Remark	Verdict
7.2	Performance requirements		
7.2.1	Operating condition		
7.2.1.1	Closing		
	For a circuit-breaker to be closed safely on to the making current corresponding to its rated short-circuit making capacity, it is essential that it should be operated with the same speed and the same firmness as during the type test for proving the short-circuit making capacity	Compliance	P
7.2.1.1.1	Dependent manual closing		
	For a circuit-breaker having a dependent manual closing mechanism, it is not possible to assign a short-circuit making capacity rating irrespective of the conditions of mechanical operation	-	N/A
	Such a circuit-breaker should not be used in circuits having a prospective peak making current exceeding 10 kA	-	N/A
	However, this does not apply in the case of a circuit-breaker having a dependent manual closing mechanism and incorporating an integral fast-acting opening release which causes the circuit-breaker to break safely, irrespective of the speed and firmness with which it is closed on to prospective peak currents exceeding 10 kA; in this case, a rated short-circuit making capacity can be assigned	-	N/A
7.2.1.1.2	Independent manual closing		
	A circuit-breaker having an independent manual closing mechanism can be assigned a short-circuit making capacity rating irrespective of the conditions of mechanical operation	Compliance	P
7.2.1.1.3	Dependent power closing		
	At 110% of the rated control supply voltage, the closing operation performed on no-load shall not cause any damage to the circuit-breaker.	-	N/A
	At 85% of the rated control supply voltage, the closing operation shall be performed when the current established by the circuit-breaker is equal to its rated making capacity within the limits allowed by the operation of its relays or releases and, if a maximum time is stated for the closing operation, in a time not exceeding this maximum time limit.	-	N/A

TRF No. IEC60947_2F

ВЯРНО С
ОРИГИНАЛА

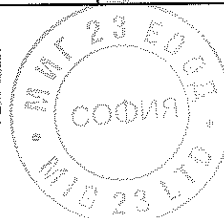

IEC 60947-2			
Clause	Requirement + Test	Result - Remark	Verdict
7.2.1.1.4	Independent power closing		
	A circuit-breaker having an independent power closing operation can be assigned a rated short-circuit making capacity irrespective of the conditions of power closing	-	N/A
	Means for charging the operating mechanism, as well as the closing control components, shall be capable of operating in accordance with the manufacturer's specification	-	N/A
7.2.1.1.5	Stored energy closing		
	Capable ensuring closing of the circuit-breaker in any condition between no-load and its rated making capacity	-	N/A
	- when the stored energy is retained within the circuit-breaker, a device is provided which indicates when the storing mechanism is fully charged.	-	N/A
	- means for charging the operating mechanism and closing control components operates when auxiliary supply voltage is between 85% and 110% of the rated control supply voltage.	-	N/A
	- not possible for the moving contacts to move from the open position, unless the charge is sufficient for satisfactory completion of the closing operation.	-	N/A
	- by manually operated circuit-breaker is the direction of operation indicated. (not for circuit-breaker with an independent manual closing operation.)	-	N/A
	- For trip free circuit-breaker it shall not be possible to maintain the contacts in the touching or closed position when the release is in the position to trip the circuit-breaker.	-	N/A



IEC 60947-2			
Clause	Requirement + Test	Result - Remark	Verdict
7.2.1.2	Opening		
7.2.1.2.1	Circuit-breakers which open automatically shall be trip-free and, unless otherwise agreed between manufacturer and user, shall have their energy for the tripping operation stored prior to the completion of the closing operation		
7.2.1.2.2	Opening by undervoltage releases		
7.2.1.3. a part 1	Operating voltage		
	An under-voltage relay or release, when associated with a switching device, shall operate to open the equipment even on a slowly falling voltage within the range between 70% and 35% of its rated voltage	-	N/A
	An under-voltage relay or release shall prevent the closing of the equipment when the supply voltage is below 35% of the rated voltage of the relay or release; it shall permit closing of the equipment at supply voltages equal to or above 85% of its rated value	-	N/A
	Unless otherwise stated in the relevant product standard, the upper limit of the supply voltage shall be 110% of its rated value	-	N/A
7.2.1.3. b part 1	Operating time		
	For a time-delay under-voltage relay or release, the time-lag shall be measured from the instant when the voltage reaches the operating value until the instant when the relay or release actuates the tripping device of the equipment	-	N/A
7.2.1.2.3	Opening by shunt releases	-	N/A
7.2.1.4 part 1	Limits of operation of shunt releases		
	A shunt release for opening shall cause tripping under all operating conditions of an equipment when the supply voltage of the shunt release measured during the tripping operation remains between 70% and 110% of the rated control supply voltage and, if a.c., at the rated frequency	-	N/A
7.2.1.5 part 1	Limits of operation of current operated relays and releases		
	Limits of operation of current operated relays and releases shall be stated in the relevant product standard	-	N/A

TRF No. IEC60947_2F

ВАРНО С
ОРИГИНАЛА

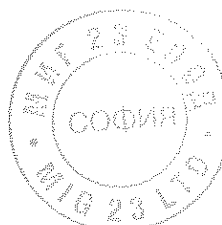

IEC 60947-2			
Clause	Requirement + Test	Result - Remark	Verdict
7.2.1.2.4	Opening by over-current releases		
a)	Opening under short-circuit conditions		
	The short-circuit release shall cause tripping of the circuit-breaker with an accuracy of 20% of the tripping current value of the current setting for all values of the current setting of the short-circuit current release	Compliance	P
	Where necessary for over-current co-ordination the manufacturer shall provide information (usually curves) showing	Compliance	P
	- maximum cut-off (let-through) peak current as a function of prospective current (r.m.s. symmetrical)	Compliance	P
	- I^2t characteristics for circuit-breakers of utilization category A and, if applicable, B for circuit-breakers with instantaneous override (see note to 8.3.5)	Compliance	P
b)	Opening under overload conditions		
1)	Instantaneous or definite time-delay operation	-	N/A
	The release shall cause tripping of the circuit-breaker with an accuracy of $\pm 10\%$ of the tripping current value of the current setting for all values of current setting of the overload release	-	N/A
2)	Inverse time-delay operation		
	At the reference temperature and at 1,05 times the current setting with the conventional non-tripping current, the opening release being energized on all poles, tripping shall not occur in less than the conventional time from the cold state, i.e. with the circuit-breaker at the reference temperature	Compliance	P
	Moreover, when at the end of the conventional time the value of current is immediately raised to 1,30 times the current setting, i.e. with the conventional tripping current, tripping shall then occur in less than the conventional time later	Compliance	P
	If a release is declared by the manufacturer as substantially independent of ambient temperature, the current values of table 6 shall apply within the temperature band declared by the manufacturer, within a tolerance of 0,3%/K	Compliance	P

TRF No. IEC60947_2F

ВЕРНО С
ОРИГИНАЛА

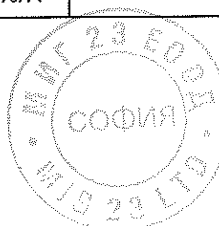

IEC 60947-2			
Clause	Requirement + Test	Result - Remark	Verdict
	The width of the temperature band shall be at least 10 K on either side of the reference temperature	Compliance	P
7.2.4.2	Operational performance capability		
7.2.4.2 part 1	The operational performance off-load for which the tests are made with the control circuits energized and the main circuit not energized, in order to demonstrate that the equipment meets the operating conditions specified at the upper and lower limits of supply voltage and/or pressure specified for the control circuit during closing and opening operations	Compliance	P
	The operational performance on-load during which the equipment shall make and break the specified current corresponding, where relevant, to its utilization category for the number of operations stated in the relevant product standard	Compliance	P
8	TESTS		
8.2.4	Mechanical properties of terminals		
	Mechanical strength of terminals		
	maximum cross-sectional area of conductor (mm ²) :	-	
	diameter of thread (mm) :	-	
	torque (Nm) :	-	
	5 times on 2 separate clamping units	-	-
	Testing for damage to and accidental loosening of conductor (flexion test)		
	conductor of the smallest cross-sectional area (mm ²) :	-	
	number of conductors of the smallest cross section :	-	
	diameter of bushing hole (mm) :	-	
	height between the equipment and the platen :	-	
	mass at the conductor(s) (kg) :	-	
	135 continuous revolutions; the conductor shall neither slip out of the terminal nor break near the clamping unit	-	N/A
	Pull-out test		
	force (N) :	-	

TRF No. IEC60947_2F

ВЕРНО С
ОРИГИНАЛОМ

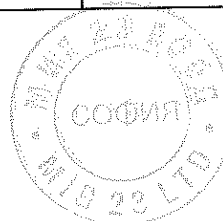

IEC 60947-2			
Clause	Requirement + Test	Result - Remark	Verdict
	1 min, the conductor shall neither slip out of the terminal nor break near the clamping unit	-	N/A
	conductor of the largest cross-sectional area (mm ²) :	-	
	number of conductors of the largest cross section :	-	
	diameter of bushing hole (mm) :	-	
	height between the equipment and the platen :		
	mass at the conductor(s) (kg) :	-	
	135 continuous revolutions: the conductor shall neither slip out of the terminal nor break near the clamping unit	-	N/A
	Pull-out test		
	force (N) :	-	
	1 min, the conductor shall neither slip out of the terminal nor break near the clamping unit	-	N/A
	conductor of the largest and smallest cross-sectional area (mm ²) :	-	
	number of conductors of the smallest cross section, number of conductors of the largest cross section :	-	
	diameter of bushing hole (mm) :	-	
	height between the equipment and the platen :	-	
	mass at the conductor(s) (kg) :	-	
	135 continuous revolutions: the conductor shall neither slip out of the terminal nor break near the clamping unit	-	N/A
	Pull-out test		
	force (N) :	-	
	1 min, the conductor shall neither slip out of the terminal nor break near the clamping unit	-	N/A

ВЕРНО С
ОРИГИНАЛА

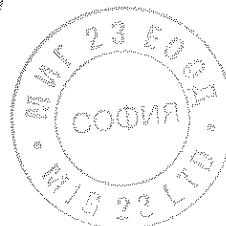

IEC 60947-2			
Clause	Requirement + Test	Result - Remark	Verdict

8.3.3	TEST SEQUENCE I: GENERAL PERFORMANCE CHARACTERISTICS		
8.3.3.1	Tripping limits and characteristic		
8.3.3.1.2	Opening under short-circuit conditions		
	Manufacturer's name or trademark	LS	
	Type designation or serial number	TS1600H 3P	
	Sample no:	S1-1	
	Rated operational voltage: Ue (V)	690 V	
	Rated current: In (A)	1600 A	
	Ambient temperature 10-40 °C :	25 °C	P
	Value of the tripping current declared by the manufacturer for a single pole, at which value they shall operate.	3840 A(Ii=2XIn) 28800 A(Ii=15XIn)	P
	Range of adjustable setting current. (A)	Compliance	P
	Time delay stated by the manufacturer, in the case of definite time delay releases.	-	N/A
	Electromagnetic overcurrent releases	-	
	Test current: 80% of the rated, or minimum adjustable setting current: (A)	-	N/A
	Operating time: >0,2s in case of instantaneous releases: L1-L2: L1-L3: L2-L3: N-Lx:	-	N/A
	Operating time: > twice time delay stated by the manufacturer, in the case of definite time delay releases: L1-L2: L1-L3: L2-L3: N-Lx:	-	N/A
	Test current: 120% of the rated, or minimum adjustable setting current: (A)	-	N/A
	Operating time: <0,2s in case of instantaneous releases: L1-L2: L1-L3: L2-L3: N-Lx:	-	N/A

ВАРНО С
ОРИГИНАЛА

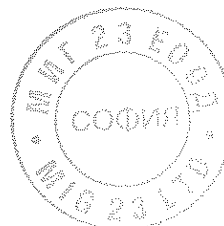

TRF No. IEC60947_2F

IEC 60947-2			
Clause	Requirement + Test	Result - Remark	Verdict
	Operating time: < twice time delay stated by the manufacturer, in the case of definite time delay releases: L1-L2: L1-L3: L2-L3: N-Lx:	-	N/A
	Test current: 80% of the maximum adjustable setting current: (A)	-	N/A
	Operating time: >0,2s in case of instantaneous releases: L1-L2: L1-L3: L2-L3: N-Lx:	-	N/A
	Operating time: > twice time delay stated by the manufacturer, in the case of definite time delay releases: L1-L2: L1-L3: L2-L3: N-Lx:	-	N/A
	Test current: 120% of the maximum adjustable setting current: (A)	Compliance	P
	Operating time: <0,2s in case of instantaneous releases: L1-L2: L1-L3: L2-L3: N-Lx:	-	N/A
	Operating time: < twice time delay stated by the manufacturer, in the case of definite time delay releases: L1-L2: L1-L3: L2-L3: N-Lx:	-	N/A
	Test current: tripping current declared for single pole operation (A)	-	N/A
	Operating time: < 0,2 s in case of instantaneous release: L1: L2: L3: N:	-	N/A
	Operating time: < twice time delay stated by manufacturer in case of definite time delay releases L1: L2: L3: N:	-	N/A
	Electronic overcurrent releases		

TRF No. IEC60947_2F

ВЕРНО С
ОРИГИНАЛА

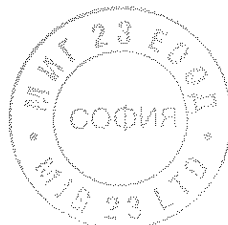

IEC 60947-2			
Clause	Requirement + Test	Result - Remark	Verdict
	For circuit-breakers with an electronic overcurrent release, the operation of the short-circuit releases shall be verified by one test only on each pole individually.	Compliance	P
	Test current: 80% of the rated, or minimum adjustable setting current: (A)	2560 A	P
	Operating time: >0,2s in case of instantaneous releases: L1: L2: L3: N:	L1: >0,2 s L2: >0,2 s L3: >0,2 s	P
	Operating time: > twice time delay stated by the manufacturer, in the case of definite time delay releases: L1: L2: L3: N:	-	N/A
	Test current: 120% of the rated, or minimum adjustable setting current: (A)	3840 A	P
	Operating time: <0,2s in case of instantaneous releases: L1: L2: L3: N:	L1: 0,048 s L2: 0,049 s L3: 0,048 s	P
	Operating time: < twice time delay stated by the manufacturer, in the case of definite time delay releases: L1: L2: L3: N:	-	N/A
	Test current: 80% of the maximum adjustable setting current: (A)	19200 A	P
	Operating time: >0,2s in case of instantaneous releases: L1: L2: L3: N:	L1: >0,2 s L2: >0,2 s L3: >0,2 s	P
	Operating time: > twice time delay stated by the manufacturer, in the case of definite time delay releases: L1: L2: L3: N:	-	N/A
	Test current: 120% of the maximum adjustable setting current: (A)	28800 A	P

TRF No. IEC60947_2F

ВЕРНО С
ОРИГИНАЛА

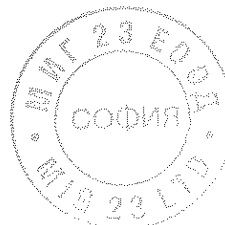

IEC 60947-2			
Clause	Requirement + Test	Result - Remark	Verdict
	Operating time: <0,2s in case of instantaneous releases: L1: L2: L3: N:	L1: 0,051 s L2: 0,052 s L3: 0,051 s	P
	Operating time: < twice time delay stated by the manufacturer, in the case of definite time delay releases: L1: L2: L3: N:	-	N/A
	Electronic overcurrent releases		
	For circuit-breakers with an electronic overcurrent release, the operation of the short-circuit releases shall be verified by one test only on each pole individually.	Compliance	P
	Test current: 80% of the rated, or minimum adjustable setting current: (A)	768 A(Isd=1,5X0,4XIn)	P
	Operating time: >0,2s in case of instantaneous releases: L1: L2: L3: N:	-	N/A
	Operating time: > twice time delay stated by the manufacturer, in the case of definite time delay releases: L1: L2: L3: N:	L1: >0,1 s L2: >0,1 s L3: >0,1 s	P
	Test current: 120% of the rated, or minimum adjustable setting current: (A)	1152 A(Isd=1,5X0,4XIn)	P
	Operating time: <0,2s in case of instantaneous releases: L1: L2: L3: N:	-	N/A
	Operating time: < twice time delay stated by the manufacturer, in the case of definite time delay releases: L1: L2: L3: N:	L1: 0,068 s L2: 0,068 s L3: 0,063 s	P
	Test current: 80% of the maximum adjustable setting current: (A)	12800 A(Isd=10X1,0XIn)	P

TRF No. IEC60947_2F

ВЕРНО С
ОРИГИНАЛА

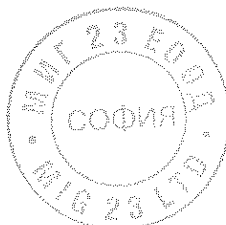

IEC 60947-2			
Clause	Requirement + Test	Result - Remark	Verdict
	Operating time: >0,2s in case of instantaneous releases: L1: L2: L3: N:	-	N/A
	Operating time: > twice time delay stated by the manufacturer, in the case of definite time delay releases: L1: L2: L3: N:	L1: >0,8 s L2: >0,8 s L3: >0,8 s	N/A
	Test current: 120% of the maximum adjustable setting current: (A)	19200 A(I _{sd} =10X1,0X _{In})	P
	Operating time: <0,2s in case of instantaneous releases: L1: L2: L3: N:	-	N/A
	Operating time: < twice time delay stated by the manufacturer, in the case of definite time delay releases: L1: L2: L3: N:	L1: 0,417 s L2: 0,417 s L3: 0,417 s	P
8.3.3.1.3	Opening under overload conditions		
a)	Instantaneous or definite time-delay releases		
	Manufacturer's name or trademark		
	Type designation or serial number		
	Sample no:		
	Rated operational voltage: U _e (V)		
	Rated current: I _n (A)		
	Ambient temperature 10-40 °C :	-	N/A
	Value of the tripping current declared by the manufacturer for a single pole, at which value they shall operate.	-	N/A
	Range of adjustable setting current. (A)	-	N/A
	Time delay stated by the manufacturer, in the case of definite time delay releases.	-	N/A
	Test current: 90% of the rated, or minimum adjustable setting current: (A)	-	N/A

TRF No. IEC60947_2F

ВЕРНО С
ОРИГИНАЛА

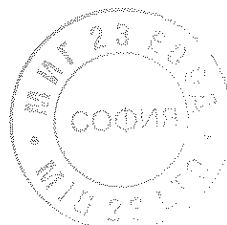

IEC 60947-2			
Clause	Requirement + Test	Result - Remark	Verdict
	Operating time: >0,2s in case of instantaneous releases:	-	N/A
	Operating time: > twice time delay stated by the manufacturer, in the case of definite time delay releases.	-	N/A
	Test current: 90% of the maximum adjustable setting current: (A)	-	N/A
	Operating time: >0,2s in case of instantaneous releases	-	N/A
	Operating time: > twice time delay stated by the manufacturer, in the case of definite time delay releases.	-	N/A
	Test current: 110% of the rated, or minimum adjustable setting current: (A) circuit-breaker with neutral pole: 1,2x110% (A)	-	N/A
	Operating time: <0,2s in case of instantaneous releases:	-	N/A
	Operating time: < twice time delay stated by the manufacturer, in the case of definite time delay releases.	-	N/A
	Test current: 110% of the maximum adjustable setting current: (A) circuit-breaker with neutral pole: 1,2x110% (A)	-	N/A
	Operating time: <0,2s in case of instantaneous releases	-	N/A
	Operating time: < twice time delay stated by the manufacturer, in the case of definite time delay releases.	-	N/A
b)	Inverse time delay releases		
	Manufacturer's name or trademark	LS	
	Type designation or serial number	TS1600H 3P	
	Sample no:	S1-1	
	Rated operational voltage: Ue (V)	690 V	
	Rated current: In (A)	1600 A	
	For releases dependent of ambient air temperature: Reference temperature	-	N/A
	Test ambient temperature (°C)	-	N/A

TRF No. IEC60947_2F

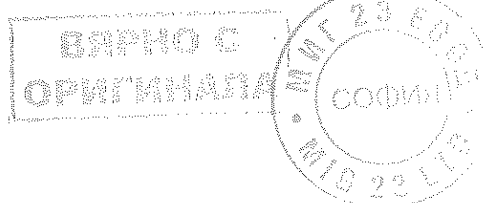

IEC 60947-2			
Clause	Requirement + Test	Result - Remark	Verdict
	For releases dependent on ambient air temperature, the operating characteristics shall be verified at the reference temperature, the release being energized on all phase poles. If the test made at a different ambient temperature, a correction shall be made in accordance with the manufacturer's correction temperature/current data	-	N/A
	For thermal-magnetic releases independent of ambient temperature: Tests shall be made at 30°C and 20°C or 40°C, the release being energized on all phase poles	-	N/A
	For electronic releases, the operating characteristic shall be verified at the ambient temperature of the test room (see 6.1.1 of IEC 60947-1), the release being energized on all phase poles.	Compliance	P
	Test ambient air temperature:	25 °C	P
	Range of adjustable setting current: (A)	0,4~1,0 x I _n	P
	Releases, dependent of ambient air temperature: Reference temperature (°C)	-	N/A
	Thermal Magnetic releases, independent of ambient air temperature: at 30°C	-	N/A
	Test current: 105% of the rated, or minimum adjustable setting current: (A)	672 A (I _r =0,4X I _n)	P
	Conventional non-tripping time: 1h when I _n < 63A, 2h when I _n > 63 A	2 h	P
	Test current: 130% of the rated, or minimum adjustable setting current: (A)	832 A (I _r =0,4X I _n)	P
	For circuit-breakers having an identified neutral pole provided with an overload release (see 8.3.3.1.1), the test current at the conventional tripping current shall be multiplied by the factor 1,2.	-	N/A
	Conventional tripping time: <1h when I _n < 63A, <2h when I _n > 63 A	4 s	P
	Test current: 105% of the maximum adjustable setting current: (A)	1680 A (I _r =1,0X I _n)	P
	Conventional non-tripping time: 1h when I _n < 63A, 2h when I _n > 63 A	2 h	P
	Test current: 130% of the maximum adjustable setting current: (A)	2080 A (I _r =1,0X I _n)	P
	For circuit-breakers having an identified neutral pole provided with an overload release (see 8.3.3.1.1), the test current at the conventional tripping current shall be multiplied by the factor 1,2.	-	N/A

TRF No. IEC60947_2F

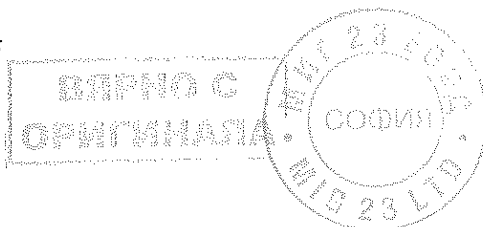

IEC 60947-2			
Clause	Requirement + Test	Result - Remark	Verdict
	Conventional tripping time: <1h when $I_n < 63A$, <2h when $I_n > 63 A$	247 s	P
	Thermal Magnetic releases, independent of ambient air temperature: at 20°C or 40°C		
	Test ambient air temperature:	-	N/A
	Test current: 105% of the rated, or minimum adjustable setting current: (A)	-	N/A
	Conventional non-tripping time: 1h when $I_n < 63A$, 2h when $I_n > 63 A$	-	N/A
	Test current: 130% of the rated, or minimum adjustable setting current: (A)	-	N/A
	For circuit-breakers having an identified neutral pole provided with an overload release (see 8.3.3.1.1), the test current at the conventional tripping current shall be multiplied by the factor 1,2.	-	N/A
	Conventional tripping time: <1h when $I_n < 63A$, <2h when $I_n > 63 A$	-	N/A
	Test current: 105% of the maximum adjustable setting current: (A)	-	N/A
	Conventional non-tripping time: 1h when $I_n < 63A$, 2h when $I_n > 63 A$	-	N/A
	Test current: 130% of the maximum adjustable setting current: (A)	-	N/A
	For circuit-breakers having an identified neutral pole provided with an overload release (see 8.3.3.1.1), the test current at the conventional tripping current shall be multiplied by the factor 1,2.	-	N/A
	Conventional tripping time: <1h when $I_n < 63A$, <2h when $I_n > 63 A$	-	N/A
	An additional test, at a current specified by the manufacturer to verify the time/current characteristic of the releases conform to the curves provided by the manufacturer		
	Releases, dependent of ambient air temperature: Reference temperature (°C)	-	N/A
	Releases, independent of ambient air temperature: at 30°C	Compliance	P
	Test ambient air temperature:	25 °C	N/A
	Test current: at current specified by the manufacturer to verify the time/current characteristic of the releases conform to the curves provided by the manufacturer. % at the rated, or minimum adjustable setting current: (% or A)	1920 A (0,4 I_n X 300 %) 4800 A (1,0 I_n X 300 %)	P

TRF No. IEC60947_2F

ВЕРНО С
ОРИГИНАЛА

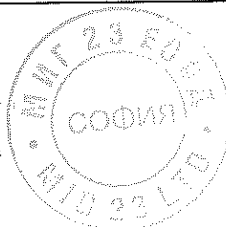

IEC 60947-2			
Clause	Requirement + Test	Result - Remark	Verdict
	Tripping time acc. time/current characteristic of the releases conform to the curves provided by the manufacturer. (within the stated tolerances)	2 s (0,4 In) 88 s (1,0 In)	P
	Releases, independent of ambient air temperature: at 20°C or 40°C		
	Test ambient air temperature:	-	N/A
	Test current: at current specified by the manufacturer to verify the time/current characteristic of the releases conform to the curves provided by the manufacturer. % at the rated, or minimum adjustable setting current: (% or A)	-	N/A
	Tripping time acc. time/current characteristic of the releases conform to the curves provided by the manufacturer. (within the stated tolerances)	-	N/A
8.3.3.1.4	Additional test for definite time-delay releases		
a)	Time delay		
	Test is made at a current equal to 1,5 times the current setting. If the test current overlaps with another tripping characteristic (e.g. an instantaneous tripping characteristic), the trip setting and the test current shall be reduced as necessary to prevent premature tripping.		
	<u>overload releases</u> : (all phase poles loaded)	-	N/A
	for circuit-breakers having an identified neutral pole provided with an overload release, the test current for this release shall be 1,5 times the current setting;	-	N/A
	<u>short-circuit releases</u>	Compliance	P
	Electromagnetic release: two poles in series carrying the test current, using successively all possible combinations of poles having a short-circuit release.	-	N/A
	Electronic releases: on one pole chosen at random.	Compliance	P
	Test current: 1,5 times of the rated, or minimum adjustable setting current: (A)	1440 A (I _{sd} =1,5X0,4XIn)	P
	Operating time, <u>overload releases</u> : (s)	-	N/A
	Time-delay: between the limits stated by the manufacturer:	-	N/A
	Operating time, <u>short-circuit releases</u> (electromagnetic): (s) L1-L2: L1-L3: L2-L3:	-	N/A
	Time-delay: between the limits stated by the manufacturer:	-	N/A

TRF No. IEC60947_2F

ВЕРНО С
ОРИГИНАЛА



IEC 60947-2			
Clause	Requirement + Test	Result - Remark	Verdict
	Operating time, <u>short-circuit releases (electronic)</u> : (s) L1: L2: L3:	L1:0,069 s L2:0,060 s L3:0,063 s	P
	Time-delay: between the limits stated by the manufacturer:	0,025 s ~ 0,08 s	P
	Test current: 1,5 times of the maximum adjustable setting current: (A)	24000 A (I _{sd} =10X1,0X _{ln})	P
	Operating time, <u>overload releases</u> : (s)	-	N/A
	Time-delay: between the limits stated by the manufacturer:	-	N/A
	Operating time, <u>short-circuit releases (electromagnetic)</u> : (s) L1-L2: L1-L3: L2-L3:	-	N/A
	Time-delay: between the limits stated by the manufacturer:	-	N/A
	Operating time, <u>short-circuit releases (electronic)</u> : (s) L1: L2: L3:	L1:0,417 s L2:0,418 s L3:0,418 s	P
	Time-delay: between the limits stated by the manufacturer:	0,36 ~ 0,44 s	P
b)	Non-tripping duration		
	Firstly, the test current equal to 1,5 times the current setting is maintained for a time interval equal to the non-tripping duration stated by the manufacturer.		
	Then, the current is reduced to the rated current and maintained at this value for twice the time-delay stated by the manufacturer. The circuit-breaker shall not trip.		
	<u>overload releases</u> : (all phase poles loaded)	-	N/A
	for circuit-breakers having an identified neutral pole provided with an overload release, the test current for this release shall be 1,5 times the current setting;	-	N/A
	<u>short-circuit releases</u>	Compliance	P
	Electromagnetic release: two poles in series carrying the test current, using successively all possible combinations of poles having a short-circuit release.	-	N/A
	Electronic releases: on one pole chosen at random.	Compliance	P
	Test current: 1,5 times of the minimum adjustable setting current: (A)	1440 A (I _{sd} =1,5X0,4X _{ln})	P

TRF No. IEC60947_2F

ВЕРНО С
ОРИГИНАЛА

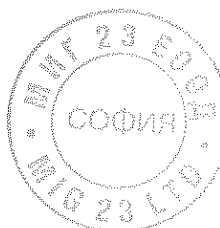

IEC 60947-2			
Clause	Requirement + Test	Result - Remark	Verdict
	non-tripping duration stated by the manufacturer for overload release: (s)	-	N/A
	non-tripping duration stated by the manufacturer for short-circuit release thermal magnetic: (s)	-	N/A
	non-tripping duration stated by the manufacturer for short-circuit release electronic: (s)	0,025 s	P
	Time duration of current when reduced to the rated current: shall be twice the delay-time stated by the manufacturer: (s)	0,1 s	P
	Rated current	640 A ($I_r=0,4X I_n$)	P
	Operating time, <u>overload releases</u> : the circuit-breaker does not trip:	-	N/A
	Operating time, <u>short-circuit releases (electromagnetic), shall not trip</u> : (s) L1-L2: L1-L3: L2-L3:	-	N/A
	Operating time, <u>short-circuit releases (electronic), shall not trip</u> : (s) L1: L2: L3:	L1: >0,1 s L2: >0,1 s L3: >0,1 s	P
	Test current: 1,5 times of maximum adjustable setting current: (A)	24000 A ($I_{sd}=10X I_n$)	P
	non-tripping duration stated by the manufacturer for overload release: (s)	-	N/A
	non-tripping duration stated by the manufacturer for short-circuit release thermal magnetic: (s)	-	N/A
	non-tripping duration stated by the manufacturer for short-circuit release electronic: (s)	0,2 s	P
	Time duration of current when reduced to the rated current: shall be twice the delay-time stated by the manufacturer: (s)	0,8 s	P
	Rated current	1600 A ($I_r=1,0X I_n$)	P
	Operating time, <u>overload releases</u> : the circuit-breaker does not trip:	-	N/A
	Operating time, <u>short-circuit releases (electromagnetic), shall not trip</u> : (s) L1-L2: L1-L3: L2-L3:	-	N/A
	Operating time, <u>short-circuit releases (electronic), shall not trip</u> : (s) L1: L2: L3:	L1: >0,8 s L2: >0,8 s L3: >0,8 s	P

TRF No. IEC60947_2F

ВАРНО С
ОРИГИНАЛА

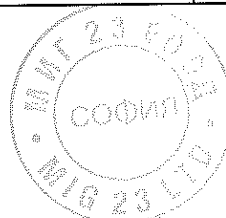

IEC 60947-2			
Clause	Requirement + Test	Result - Remark	Verdict
8.3.3.2	Test of dielectric properties, impulse withstand voltage (Uimp indicated):		
8.3.3.4 part1	The 1,2/50µs impulse voltage shall be applied five times for each polarity at intervals of 1s minimum		
	- rated impulse withstand voltage (kV) :	8 kV	P
	- sea level of the laboratory:	60 m	P
	- test Uimp main circuits (kV) :	9,8 kV	P
	- test Uimp auxiliary circuits (kV) :	-	N/A
	- test Uimp control circuits (kV) :	-	N/A
	- test Uimp on open main contacts (equipment suitable for isolating) (kV) :	12,3 kV	P
a)	Application of test voltage		
	i) Between all terminals of the main circuit connected together (incl. control and auxiliary circuits connected to the main circuit) and the enclosure or mounting plate, with the contacts in all normal positions of operation.	Compliance	P
	ii) Between each pole of the main circuit and the other poles connected together and to the enclosure or mounting plate, with the contacts in all normal positions of operation.	Compliance	P
	iii) Between each control and auxiliary circuit not normally connected to the main circuit and: - the main circuit	Compliance	P
	- other circuits	-	N/A
	- exposed conductive parts	-	N/A
	- enclosure of mounting plate	-	N/A
	iv) equipment suitable for isolation	Compliance	P
	equipment not suitable for isolation	-	N/A
	- no unintentional disruptive discharge during the test's	Compliance	P
	Test of dielectric properties, dielectric withstand voltage (Uimp not indicated):		
	- rated insulation voltage (V) :	1000 V	P
	- main circuits, test voltage for 1 min (V)	2200 V	P
	- auxiliary circuits, test voltage for 1 min (V)	-	N/A
	- control circuits, test voltage for 1 min (V)	-	N/A

TRF No. IEC60947_2F

ВЕРНО С
ОРИГИНАЛА

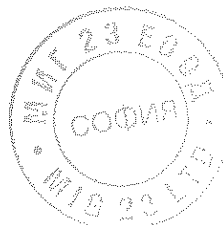

IEC 60947-2			
Clause	Requirement + Test	Result - Remark	Verdict
8.3.3.2.2	Application of test voltage		
1)	with circuit-breaker in the closed position		
	- between all live parts of all poles connected together and the frame of the circuit-breaker .	Compliance	P
	- between each pole and all the other poles connected to the frame of the circuit-breaker	Compliance	P
2)	with the circuit-breaker in the open position and, additionally, in the tripped position, if any.		
	- between all live parts of all poles connected together and the frame of the circuit-breaker.	Compliance	P
	- between the terminals of one side connected together and the terminals of the other side connected together.	Compliance	P
b)	Control and auxiliary circuits		
1)	- between all the control and auxiliary circuits which are not normally connected to the main circuit, connected together, and the frame of the circuit-breaker.	-	N/A
2)	- where appropriate, between each part of the control an auxiliary circuits which may be isolated from the other parts during normal operation and all the other parts connected together.	-	N/A
	No unintentional disruptive discharge during the tests	Compliance	P
8.3.3.2	For circuit-breaker suitable for isolation, the leakage current shall be measured through each pole with the contacts in the open position, at a test voltage of 1,1 Ue, and shall not exceed 0,5mA.	≤ 0,01 mA./ 759 V	P
8.3.3.3	Mechanical operation and operational performance capability		
8.3.3.3.2	Construction and mechanical operation		
a)	Construction		
	A withdrawable circuit-breaker shall be checked for the requirements stated in 7.1.1	-	N/A
	A circuit-breaker with stored energy operation shall be checked for compliance with 7.2.1.1.5, regarding the charge indicator and the direction of operation of manual energy storing	-	N/A
b)	Mechanical operation		
	A circuit-breaker with dependent power operation shall comply with the requirements stated in 7.2.1.1.3	-	N/A

TRF No. IEC60947_2F

ВЕРНО С
ОРИГИНАЛА

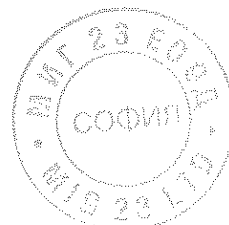



IEC 60947-2			
Clause	Requirement + Test	Result - Remark	Verdict
	A circuit-breaker with dependent power operation shall operate with the operating mechanism charged to the minimum and maximum limits stated by the manufacturer	-	N/A
	A circuit-breaker with stored energy operation shall comply with the requirements stated in 7.2.1.5 with the auxiliary supply voltage at 85% and 110% of the rated control supply voltage.	-	N/A
	It shall also be verified that the moving contacts cannot be moved from the open position when the operating mechanism is charged to slightly below the full charge as evidenced by the indicating device	-	N/A
	For a trip-free circuit-breaker it shall not be possible to maintain the contacts in the touching or closed position when the tripping release is in the position to trip the circuit-breaker	-	N/A
	If the closing and opening times of a circuit-breaker are stated by the manufacturer, such times shall comply with the stated values	-	N/A
c)	Undervoltage releases		
	Undervoltage releases shall comply with the requirements of 7.2.1.3 of Part 1. For this purpose, the release shall be fitted to a circuit-breaker having the maximum current rating for which the release is suitable	-	N/A
i)	Drop out voltage		
	It shall be verified that the release operates to open the circuit-breaker between the voltage limits specified	-	N/A
	The voltage shall be reduced from rated voltage at a rate to reach 0 V in approximately 30 s	-	N/A
	The test for the lower limit is made without current in the main circuit and without previous heating of the release coil	-	N/A
	In the case of a release with a range of rated voltages, this test applies to the maximum voltage of the range	-	N/A
	The test for the upper limit is made starting from a constant temperature corresponding to the application of rated control supply voltage to the release and rated current in the main poles of the circuit-breaker	-	N/A
	This test may be combined with the temperature-rise test of 8.3.3.6	-	N/A

TRF No. IEC60947_2F

ВЯРНО С
ОРИГИНАЛА

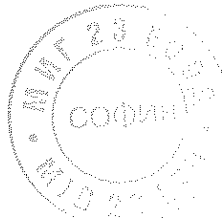

IEC 60947-2			
Clause	Requirement + Test	Result - Remark	Verdict
	In the case of a release with a range of rated voltages, this test is made at both the minimum and maximum rated control supply voltages	-	N/A
ii)	Test for limits of operation		
	Starting with the circuit-breaker open, at the temperature of the test room, and with the supply voltage at 30% rated maximum control supply voltage, it shall be verified that the circuit-breaker cannot be closed by the operation of the actuator	-	N/A
	When the supply voltage is raised to 85% of the minimum control supply voltage, it shall be verified that the circuit-breaker can be closed by the operation of the actuator	-	N/A
iii)	Performance under overvoltage conditions		
	With the circuit-breaker closed and without current in the main circuit, it shall be verified that the undervoltage release will withstand the application of 110% rated control supply voltage for 4 h without impairing its functions	-	N/A
d)	Shunt releases		
	Shunt releases shall comply with the requirements of 7.2.1.4 of Part 1. For this purpose, the release shall be fitted to a circuit-breaker having the maximum rated current for which the release is suitable	-	N/A
	It shall be verified that the release will operate to open the circuit-breaker at 70% rated control supply voltage when tested at an ambient temperature of $+ 55\text{ }^{\circ}\text{C} \pm 2\text{ }^{\circ}\text{C}$ without current in the main poles of the circuit-breaker	-	N/A
	In the case of a release having a range of rated control supply voltages, the test voltage shall be 70% of the minimum rated control supply voltage	-	N/A
8.3.3.3.3	Operational performance capability without current.		
	Type designation or serial number	TS1600H 3P	
	Sample no:	S1-1	
	Rated current I_n (A)	1600 A	
	Rated operational voltage: U_e (V)	690 V	
	Rated control supply voltage of closing mechanism: U_c (V)		
	Rated control supply voltage of shunt releases: U_c (V)		

TRF No. IEC60947_2F

ВЯРНО С
ОРИГИНАЛА

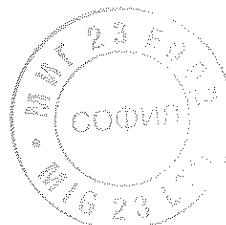

IEC 60947-2			
Clause	Requirement + Test	Result - Remark	Verdict
	Rated control supply voltage undervoltage releases: U _c (V)		
	Ambient temperature 10-40 °C :	25 °C	P
	Number of operating cycles per hour	20 Cycles per hour	P
	Number of cycles without current (total) (closing mechanism energized at the rated U _c)	-	N/A
	Number of cycles without current (without releases)	2500 Cycles	P
	Applied voltage: closing mechanism (V)	-	N/A
	10% of total cycles for circuit-breaker with fitted shunt release: (50% at the beginning- and 50% at the end of the test.) Energized at the rated U _c	-	N/A
	Applied voltage: shunt releases (V)	-	N/A
	10% of total cycles for circuit-breaker with undervoltage releases: (50% at the beginning- and 50% at the end of the test.) Energized at the minimum rated U _c	-	N/A
	10 cycles without applied voltage at the undervoltage releases. (Shall not possible to close the circuit-breaker.)	-	N/A
	Applied voltage: undervoltage releases (V)	-	N/A
	Electrical components do not exceed the value indicated in tab. 7.	Compliance	P
8.3.3.3.4	Operational performance capability with current.		
	Rated current: I _n (A)	1600 A	
	Maximum rated operational voltage: U _e (V)	690 V	
	Conductor cross-sectional area (mm ²) :	500 mm ² X 2	P
	Number of operating cycles per hour	20 Cycles per hour	P
	Number of cycles with current (total) (closing mechanism energized at the rated U _c)	500 Cycles	P
	Applied voltage: closing mechanism (V)	-	N/A
	For circuit-breaker fitted with adjustable releases, test shall be made with the overload setting at maximum and short-circuit setting at minimum.	Compliance	P
	Conditions, make/break operations:		
	- test voltage U/U _e = 110 (V) L1: L2: L3:	L1: 691,8 V L2: 700,8 V L3: 708,3 V	P

TRF No. IEC60947_2F

ВАРНО С
ОРИГИНАЛ

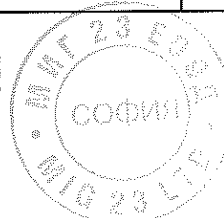

IEC 60947-2			
Clause	Requirement + Test	Result - Remark	Verdict
	- test current I/le = 1,0 (A)..... L1: L2: L3:	L1: 1618 A L2: 1625 A L3: 1602 A	P
	- power factor/time constant:	0,73	P
	- frequency: (Hz)	60 Hz	P
	- on-time (ms):	1000 ms	P
	- off-time (s):	179 s	P
	Electrical components do not exceed the value indicated in tab. 7.	Compliance	P
8.3.3.3.5	Additional test of operational performance capability without current for withdrawable circuit-breaker.		
	Number of operations cycles : 100	-	N/A
	After test, the isolating contacts, withdrawable mechanism and interlocks shall be suitable for further service.	-	N/A
8.3.3.4	Overload performance		
	this test applies to circuit-breaker of rated current up to and including 630 A		
	Type designation or serial number		
	Sample no:		
	Rated current In (A)		
	Rated operational voltage: Ue (V)		
	Rated control supply voltage of closing mechanism: Uc (V)		
	Rated control supply voltage of shunt releases: Uc (V)		
	Rated control supply voltage undervoltage releases: Uc (V)		
	Ambient temperature 10-40 °C :	-	N/A
	Number of operating cycles per hour	-	N/A
	Maximum rated operational voltage: Ue (V)	-	N/A
	Number of operating cycles per hour	-	N/A
	Number of cycles with current (total) (closing mechanism energized at the rated Uc)	-	N/A
	Applied voltage: closing mechanism (V)	-	N/A

TRF No. IEC60947_2F

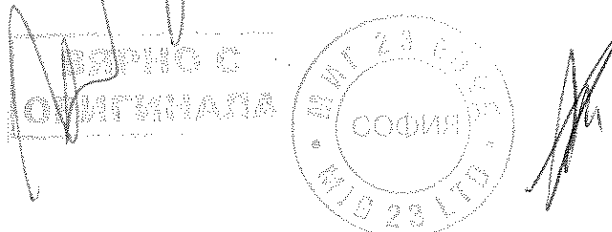

IEC 60947-2			
Clause	Requirement + Test	Result - Remark	Verdict
	For circuit-breaker fitted with adjustable releases, test shall be made with the overload/short-circuit settings at maximum.	-	N/A
	Conditions, overload operations:		
	- test voltage $U/U_e = 1,05$ (V) L1: L2: L3:	-	N/A
	- test current AC/DC: $I/I_e = 6,0/2.5$ (A) L1: L2: L3:	-	N/A
	- power factor/time constant:	-	N/A
	- Number of cycles manually opened: 9	-	N/A
	- Number of cycles automatically opened by an overload release: 3	-	N/A
	- frequency: (Hz)	-	N/A
	- on-time max 2s:	-	N/A
8.3.3.5	Verification of dielectric withstand		
	- equal to twice the rated operational voltage with a minimum of 1000 V for 5 seconds	1380 V	P
	- no breakdown or flashover	No	P
	For circuit-breaker suitable for isolation, the leakage current shall be measured through each pole with the contacts in the open position, at a test voltage of $1,1 U_e$, and shall not exceed 2 mA.	$\leq 0,02$ mA / 759 V	P
8.3.3.6	Verification of temperature-rise		
****	- the values of temperature-rise do not exceed those specified in tab. 7.	See table S1-1 (3P)	P
	Temperature rise of main circuit terminals ≤ 80 K (K) :	$\leq 73,3$ K	P
	conductor cross-sectional area (mm ²) :	500 mm ² x 2	P
	test current I_e (A) :	1600 A	P
8.3.3.7	Verification of overload releases		
	Test current: 1.45 times the value of their current setting at the reference temperature: (A)	2320 A	P
	Conventional tripping time: <1h when $I_n < 63$ A, <2h when $I_n > 63$ A	542 s	P

TRF No. IEC60947_2F

ВЕРНО С
ОРИГИНАЛА



IEC 60947-2			
Clause	Requirement + Test	Result - Remark	Verdict
8.3.3.8	Verification of undervoltage and shunt releases		
	Circuit-breaker fitted with undervoltage releases. The release shall not operate at 70% of the minimum control supply voltage -	-	N/A
	and shall operate at 35% of the maximum control supply voltage.	-	N/A
	Circuit-breaker fitted with shunt releases. The release shall operate at 70% of the minimum rated control supply voltage. Test made at room temperature.	-	N/A
8.3.3.9	Verification of the main contact position for circuit-breakers for isolation		
	actuating force for opening (N)	206 N	—
	test force with blocked main contacts for 10 s (N) ..	618 N	—
	Dependent power operation	-	N/A
	Supply voltage of 110% of rated voltage (V).....	-	N/A
	Three attempts of 5 s to operate the equipment at intervals of 5 min.	-	N/A
	Independent power operation	-	N/A
	Three attempts to operate the equipment by the stored energy.	-	N/A
	Lock ability of driving mechanism in OFF-position at test force and blocked main contacts	-	N/A
	Position indicator does not show OFF-position after capture of test force at blocked main contacts	Compliance	P

8.3.3	TEST SEQUENCE I: GENERAL PERFORMANCE CHARACTERISTICS		
8.3.3.1	Tripping limits and characteristic		
8.3.3.1.2	Opening under short-circuit conditions		
	Manufacturer's name or trademark	LS	
	Type designation or serial number	TS1600H 4P	
	Sample no:	S1-1	
	Rated operational voltage: U _e (V)	690 V	
	Rated current: I _n (A)	1600 A	
	Ambient temperature 10-40 °C :	25 °C	P

TRF No. IEC60947_2F

ВЪРНО С
ОРИГИНАЛА

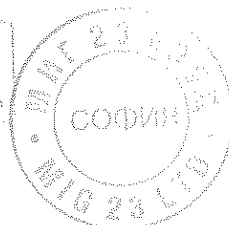

IEC 60947-2			
Clause	Requirement + Test	Result - Remark	Verdict
	Value of the tripping current declared by the manufacturer for a single pole, at which value they shall operate.	3840 A($I_i=2X I_n$) 28800 A($I_i=15X I_n$)	P
	Range of adjustable setting current. (A)	Compliance	P
	Time delay stated by the manufacturer, in the case of definite time delay releases.	-	N/A
	Electromagnetic overcurrent releases		
	Test current: 80% of the rated, or minimum adjustable setting current: (A)	-	N/A
	Operating time: >0,2s in case of instantaneous releases: L1-L2: L1-L3: L2-L3: N-Lx:	-	N/A
	Operating time: > twice time delay stated by the manufacturer, in the case of definite time delay releases: L1-L2: L1-L3: L2-L3: N-Lx:	-	N/A
	Test current: 120% of the rated, or minimum adjustable setting current: (A)	-	N/A
	Operating time: <0,2s in case of instantaneous releases: L1-L2: L1-L3: L2-L3: N-Lx:	-	N/A
	Operating time: < twice time delay stated by the manufacturer, in the case of definite time delay releases: L1-L2: L1-L3: L2-L3: N-Lx:	-	N/A
	Test current: 80% of the maximum adjustable setting current: (A)	-	N/A
	Operating time: >0,2s in case of instantaneous releases: L1-L2: L1-L3: L2-L3: N-Lx:	-	N/A

BRNO C
OPVIGINARA

MIG 23 LTD
COFMA
MIG 23 LTD

IEC 60947-2			
Clause	Requirement + Test	Result - Remark	Verdict
	Operating time: > twice time delay stated by the manufacturer, in the case of definite time delay releases: L1-L2: L1-L3: L2-L3: N-Lx:	-	N/A
	Test current: 120% of the maximum adjustable setting current: (A)	Compliance	P
	Operating time: <0,2s in case of instantaneous releases: L1-L2: L1-L3: L2-L3: N-Lx:	-	N/A
	Operating time: < twice time delay stated by the manufacturer, in the case of definite time delay releases: L1-L2: L1-L3: L2-L3: N-Lx:	-	N/A
	Test current: tripping current declared for single pole operation (A)	-	N/A
	Operating time: < 0,2 s in case of instantaneous release: L1: L2: L3: N:	-	N/A
	Operating time: < twice time delay stated by manufacturer in case of definite time delay releases L1: L2: L3: N:	-	N/A
	Electronic overcurrent releases		
	For circuit-breakers with an electronic overcurrent release, the operation of the short-circuit releases shall be verified by one test only on each pole individually.	Compliance	P
	Test current: 80% of the rated, or minimum adjustable setting current: (A)	2560 A($I_i=2 \times I_n$)	P
	Operating time: >0,2s in case of instantaneous releases: L1: L2: L3: N:	L1: >0,2 s L2: >0,2 s L3: >0,2 s N:	P

TRF No. IEC60947_2F

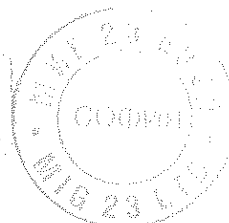
 ВІСНОК
ОРИГІНАЛА

IEC 60947-2			
Clause	Requirement + Test	Result - Remark	Verdict
	Operating time: > twice time delay stated by the manufacturer, in the case of definite time delay releases: L1: L2: L3: N:	-	N/A
	Test current: 120% of the rated, or minimum adjustable setting current: (A)	3840 A(Ii=2XIn)	P
	Operating time: <0,2s in case of instantaneous releases: L1: L2: L3: N:	L1: 0,050 s L2: 0,049 s L3: 0,049 s	P
	Operating time: < twice time delay stated by the manufacturer, in the case of definite time delay releases: L1: L2: L3: N:	-	N/A
	Test current: 80% of the maximum adjustable setting current: (A)	19200 A(Ii=15XIn)	P
	Operating time: >0,2s in case of instantaneous releases: L1: L2: L3: N:	L1: >0,2 s L2: >0,2 s L3: >0,2 s	P
	Operating time: > twice time delay stated by the manufacturer, in the case of definite time delay releases: L1: L2: L3: N:	-	N/A
	Test current: 120% of the maximum adjustable setting current: (A)	28800 A(Ii=15XIn)	P
	Operating time: <0,2s in case of instantaneous releases: L1: L2: L3: N:	L1: 0,050 s L2: 0,050 s L3: 0,049 s	P
	Operating time: < twice time delay stated by the manufacturer, in the case of definite time delay releases: L1: L2: L3: N:	-	N/A
	Electronic overcurrent releases		

TRF No. IEC60947_2F

БАРНО С
ОПРИМАННА

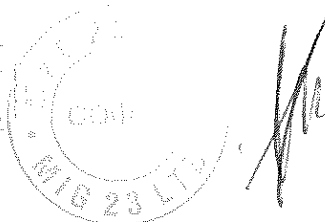

IEC 60947-2			
Clause	Requirement + Test	Result - Remark	Verdict
	For circuit-breakers with an electronic overcurrent release, the operation of the short-circuit releases shall be verified by one test only on each pole individually.	Compliance	P
	Test current: 80% of the rated, or minimum adjustable setting current: (A)	768 A(Isd=1,5X0,4XIn)	P
	Operating time: >0,2s in case of instantaneous releases: L1: L2: L3: N:	-	N/A
	Operating time: > twice time delay stated by the manufacturer, in the case of definite time delay releases: L1: L2: L3: N:	L1: >0,1 s L2: >0,1 s L3: >0,1 s	P
	Test current: 120% of the rated, or minimum adjustable setting current: (A)	1152 A(Isd=1,5X0,4XIn)	P
	Operating time: <0,2s in case of instantaneous releases: L1: L2: L3: N:	-	N/A
	Operating time: < twice time delay stated by the manufacturer, in the case of definite time delay releases: L1: L2: L3: N:	L1: 0,068 s L2: 0,072 s L3: 0,065 s	P
	Test current: 80% of the maximum adjustable setting current: (A)	12800 A(Isd=10X1,0XIn)	P
	Operating time: >0,2s in case of instantaneous releases: L1: L2: L3: N:	-	N/A
	Operating time: > twice time delay stated by the manufacturer, in the case of definite time delay releases: L1: L2: L3: N:	L1: >0,8 s L2: >0,8 s L3: >0,8 s	N/A
	Test current: 120% of the maximum adjustable setting current: (A)	19200 A(Isd=10X1,0XIn)	P

TRF No. IEC60947_2F

ВЕРНО С
ОРИГИНАЛА

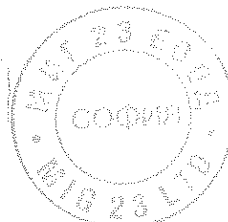

IEC 60947-2			
Clause	Requirement + Test	Result - Remark	Verdict
	Operating time: <0,2s in case of instantaneous releases: L1: L2: L3: N:	-	N/A
	Operating time: < twice time delay stated by the manufacturer, in the case of definite time delay releases: L1: L2: L3: N:	L1: 0,418 s L2: 0,418 s L3: 0,418 s	P
8.3.3.1.3	Opening under overload conditions		
a)	Instantaneous or definite time-delay releases		
	Manufacturer's name or trademark		
	Type designation or serial number		
	Sample no:		
	Rated operational voltage: Ue (V)		
	Rated current: In (A)		
	Ambient temperature 10-40 °C :	-	N/A
	Value of the tripping current declared by the manufacturer for a single pole, at which value they shall operate.	-	N/A
	Range of adjustable setting current. (A)	-	N/A
	Time delay stated by the manufacturer, in the case of definite time delay releases.	-	N/A
	Test current: 90% of the rated, or minimum adjustable setting current: (A)	-	N/A
	Operating time: >0,2s in case of instantaneous releases:	-	N/A
	Operating time: > twice time delay stated by the manufacturer, in the case of definite time delay releases.	-	N/A
	Test current: 90% of the maximum adjustable setting current: (A)	-	N/A
	Operating time: >0,2s in case of instantaneous releases	-	N/A
	Operating time: > twice time delay stated by the manufacturer, in the case of definite time delay releases.	-	N/A

TRF No. IEC60947_2F

БВРНО С
ОРИГИНАЛ



IEC 60947-2			
Clause	Requirement + Test	Result - Remark	Verdict
	Test current: 110% of the rated, or minimum adjustable setting current: (A) circuit-breaker with neutral pole: 1,2x110% (A)	-	N/A
	Operating time: <0,2s in case of instantaneous releases:	-	N/A
	Operating time: < twice time delay stated by the manufacturer, in the case of definite time delay releases.	-	N/A
	Test current: 110% of the maximum adjustable setting current: (A) circuit-breaker with neutral pole: 1,2x110% (A)	-	N/A
	Operating time: <0,2s in case of instantaneous releases	-	N/A
	Operating time: < twice time delay stated by the manufacturer, in the case of definite time delay releases.	-	N/A
b)	Inverse time delay releases		
	Manufacturer's name or trademark	LS	
	Type designation or serial number	TS1600H 4P	
	Sample no:	S1-1	
	Rated operational voltage: Ue (V)	690 V	
	Rated current: In (A)	1600 A	
	For releases dependent of ambient air temperature: Reference temperature	-	N/A
	Test ambient temperature (°C)	-	N/A
	For releases dependent on ambient air temperature, the operating characteristics shall be verified at the reference temperature, the release being energized on all phase poles. If the test made at a different ambient temperature, a correction shall be made in accordance with the manufacturer's correction temperature/current data	-	N/A
	For thermal-magnetic releases independent of ambient temperature: Tests shall be made at 30°C and 20°C or 40°C, the release being energized on all phase poles	-	N/A
	For electronic releases, the operating characteristic shall be verified at the ambient temperature of the test room (see 6.1.1 of IEC 60947-1), the release being energised on all phase poles.	Compliance	P

TRF No. IEC60947_2F

ВАРНО С
ОРИГИНАЛА

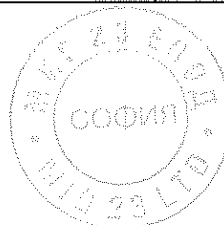

IEC 60947-2			
Clause	Requirement + Test	Result - Remark	Verdict
	Test ambient air temperature:	25 °C	P
	Range of adjustable setting current: (A)	0,4~1,0 x In	P
	Releases, dependent of ambient air temperature: Reference temperature (°C)	-	N/A
	Thermal Magnetic releases, independent of ambient air temperature: at 30°C	-	N/A
	Test current: 105% of the rated, or minimum adjustable setting current: (A)	672 A (Ir=0,4XIn)	P
	Conventional non-tripping time: 1h when In < 63A, 2h when In > 63 A	2 h	P
	Test current: 130% of the rated, or minimum adjustable setting current: (A)	832 A (Ir=0,4XIn)	P
	For circuit-breakers having an identified neutral pole provided with an overload release (see 8.3.3.1.1), the test current at the conventional tripping current shall be multiplied by the factor 1,2.	998 A (Ir=0,4XIn)	P
	Conventional tripping time: <1h when In < 63A, <2h when In > 63 A	5 s / 5 s	P
	Test current: 105% of the maximum adjustable setting current: (A)	1680 A (Ir=1,0XIn)	P
	Conventional non-tripping time: 1h when In < 63A, 2h when In > 63 A	2 h	P
	Test current: 130% of the maximum adjustable setting current: (A)	2080 A (Ir=1,0XIn)	P
	For circuit-breakers having an identified neutral pole provided with an overload release (see 8.3.3.1.1), the test current at the conventional tripping current shall be multiplied by the factor 1,2.	2496 A (Ir=1,0XIn)	P
	Conventional tripping time: <1h when In < 63A, <2h when In > 63 A	318 s / 145 s	P
	Thermal Magnetic releases, independent of ambient air temperature: at 20°C or 40°C		
	Test ambient air temperature:	-	N/A
	Test current: 105% of the rated, or minimum adjustable setting current: (A)	-	N/A
	Conventional non-tripping time: 1h when In < 63A, 2h when In > 63 A	-	N/A
	Test current: 130% of the rated, or minimum adjustable setting current: (A)	-	N/A

TRF No. IEC60947_2F

ВЯРНО С
ОРИГИНАЛА

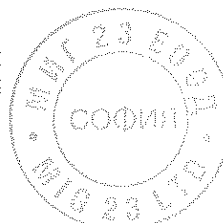

IEC 60947-2			
Clause	Requirement + Test	Result - Remark	Verdict
	For circuit-breakers having an identified neutral pole provided with an overload release (see 8.3.3.1.1), the test current at the conventional tripping current shall be multiplied by the factor 1,2.	-	N/A
	Conventional tripping time: <1h when $I_n < 63A$, <2h when $I_n > 63 A$	-	N/A
	Test current: 105% of the maximum adjustable setting current: (A)	-	N/A
	Conventional non-tripping time: 1h when $I_n < 63A$, 2h when $I_n > 63 A$	-	N/A
	Test current: 130% of the maximum adjustable setting current: (A)	-	N/A
	For circuit-breakers having an identified neutral pole provided with an overload release (see 8.3.3.1.1), the test current at the conventional tripping current shall be multiplied by the factor 1,2.	-	N/A
	Conventional tripping time: <1h when $I_n < 63A$, <2h when $I_n > 63 A$	-	N/A
	An additional test, at a current specified by the manufacturer to verify the time/current characteristic of the releases conform to the curves provided by the manufacturer		
	Releases, dependent of ambient air temperature: Reference temperature (°C)	Compliance	P
	Releases, independent of ambient air temperature: at 30°C	Compliance	P
	Test ambient air temperature:	25 °C	N/A
	Test current: at current specified by the manufacturer to verify the time/current characteristic of the releases conform to the curves provided by the manufacturer. % at the rated, or minimum adjustable setting current: (% or A)	1920 A (0,4 I_n X 300 %) 4800 A (1,0 I_n X 300 %)	P
	Tripping time acc. time/current characteristic of the releases conform to the curves provided by the manufacturer. (within the stated tolerances)	2 s (0,4 I_n) 89 s (1,0 I_n)	P
	Releases, independent of ambient air temperature: at 20°C or 40°C		
	Test ambient air temperature:	-	N/A
	Test current: at current specified by the manufacturer to verify the time/current characteristic of the releases conform to the curves provided by the manufacturer. % at the rated, or minimum adjustable setting current: (% or A)	-	N/A

TRF No. IEC60947_2F

ВЕРНО С
ОРИГИНАЛА

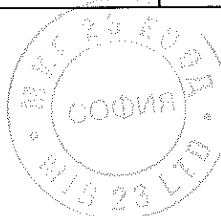

IEC 60947-2			
Clause	Requirement + Test	Result - Remark	Verdict
	Tripping time acc. time/current characteristic of the releases conform to the curves provided by the manufacturer. (within the stated tolerances)	-	N/A
8.3.3.1.4	Additional test for definite time-delay releases		
a)	Time delay		
	Test is made at a current equal to 1,5 times the current setting. If the test current overlaps with another tripping characteristic (e.g. an instantaneous tripping characteristic), the trip setting and the test current shall be reduced as necessary to prevent premature tripping.		
	<u>overload releases</u> : (all phase poles loaded)	-	N/A
	for circuit-breakers having an identified neutral pole provided with an overload release, the test current for this release shall be 1,5 times the current setting;	-	N/A
	<u>short-circuit releases</u>	Compliance	P
	Electromagnetic release: two poles in series carrying the test current, using successively all possible combinations of poles having a short-circuit release.	-	N/A
	Electronic releases: on one pole chosen at random.	Compliance	P
	Test current: 1,5 times of the rated, or minimum adjustable setting current: (A)	1440 A (I _{sd} =1,5X0,4X _{ln})	P
	Operating time, <u>overload releases</u> : (s)	-	N/A
	Time-delay: between the limits stated by the manufacturer:	-	N/A
	Operating time, <u>short-circuit releases (electromagnetic)</u> : (s) L1-L2: L1-L3: L2-L3:	-	N/A
	Time-delay: between the limits stated by the manufacturer:	-	N/A
	Operating time, <u>short-circuit releases (electronic)</u> : (s) L1: L2: L3:	L1:0,067 s L2:0,067 s L3:0,068 s	P
	Time-delay: between the limits stated by the manufacturer:	0,025 s ~ 0,08 s	P
	Test current: 1,5 times of the maximum adjustable setting current: (A)	24000 A (I _{sd} =10X1,0X _{ln})	P
	Operating time, <u>overload releases</u> : (s)	-	N/A

TRF No. IEC60947_2F

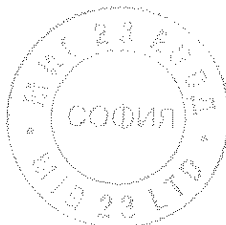
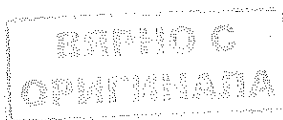

IEC 60947-2			
Clause	Requirement + Test	Result - Remark	Verdict
	Time-delay: between the limits stated by the manufacturer:	-	N/A
	Operating time, <u>short-circuit releases (electromagnetic)</u> : (s) L1-L2: L1-L3: L2-L3:	-	N/A
	Time-delay: between the limits stated by the manufacturer:	-	N/A
	Operating time, <u>short-circuit releases (electronic)</u> : (s) L1: L2: L3:	L1:0,418 s L2:0,419 s L3:0,419 s	P
	Time-delay: between the limits stated by the manufacturer:	0,36 ~ 0,44 s	P
b)	Non-tripping duration		
	Firstly, the test current equal to 1,5 times the current setting is maintained for a time interval equal to the non-tripping duration stated by the manufacturer.		
	Then, the current is reduced to the rated current and maintained at this value for twice the time-delay stated by the manufacturer. The circuit-breaker shall not trip.		
	<u>overload releases</u> : (all phase poles loaded)	-	N/A
	for circuit-breakers having an identified neutral pole provided with an overload release, the test current for this release shall be 1,5 times the current setting;	-	N/A
	<u>short-circuit releases</u>	Compliance	P
	Electromagnetic release: two poles in series carrying the test current, using successively all possible combinations of poles having a short-circuit release.	-	N/A
	Electronic releases: on one pole chosen at random.	Compliance	P
	Test current: 1,5 times of the minimum adjustable setting current: (A)	1440 A (I _{sd} =1,5X0,4XIn)	P
	non-tripping duration stated by the manufacturer for overload release: (s)	-	N/A
	non-tripping duration stated by the manufacturer for short-circuit release thermal magnetic: (s)	-	N/A
	non-tripping duration stated by the manufacturer for short-circuit release electronic: (s)	0,025 s	P
	Time duration of current when reduced to the rated current: shall be twice the delay-time stated by the manufacturer: (s)	0,1 s	P

TRF No. IEC60947_2F

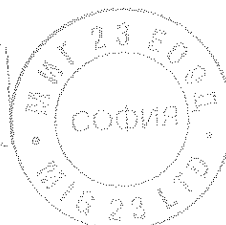

ВАРНО С
ОРИГИНАЛА



IEC 60947-2			
Clause	Requirement + Test	Result - Remark	Verdict
	Rated current	640 A ($I_r=0,4X I_n$)	P
	Operating time, <u>overload releases</u> : the circuit-breaker does not trip:	-	N/A
	Operating time, <u>short-circuit releases</u> (electromagnetic), shall not trip: (s) L1-L2: L1-L3: L2-L3:	-	N/A
	Operating time, <u>short-circuit releases (electronic)</u> , shall not trip: (s) L1: L2: L3:	L1: >0,1 s L2: >0,1 s L3: >0,1 s	P
	Test current: 1,5 times of maximum adjustable setting current: (A)	24000 A ($I_{sd}=10X I_n$)	P
	non-tripping duration stated by the manufacturer for overload release: (s)	-	N/A
	non-tripping duration stated by the manufacturer for short-circuit release thermal magnetic: (s)	-	N/A
	non-tripping duration stated by the manufacturer for short-circuit release electronic: (s)	0,2 s	P
	Time duration of current when reduced to the rated current: shall be twice the delay-time stated by the manufacturer: (s)	0,8 s	P
	Rated current	1600 A ($I_r=1,0X I_n$)	P
	Operating time, <u>overload releases</u> : the circuit-breaker does not trip:	-	N/A
	Operating time, <u>short-circuit releases</u> (electromagnetic), shall not trip: (s) L1-L2: L1-L3: L2-L3:	-	N/A
	Operating time, <u>short-circuit releases (electronic)</u> , shall not trip: (s) L1: L2: L3:	L1: >0,8 s L2: >0,8 s L3: >0,8 s	P
8.3.3.2	Test of dielectric properties, impulse withstand voltage (U_{imp} indicated):		
8.3.3.4 part1	The 1,2/50 μ s impulse voltage shall be applied five times for each polarity at intervals of 1s minimum		
	- rated impulse withstand voltage (kV) :	8 kV	P
	- sea level of the laboratory:	60 m	P
	- test U_{imp} main circuits (kV) :	9,8 kV	P
	- test U_{imp} auxiliary circuits (kV) :	-	N/A

TRF No. IEC60947_2F

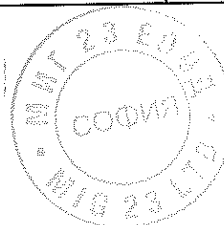
ВЯРВО С
ОРИГИНАЛА

IEC 60947-2			
Clause	Requirement + Test	Result - Remark	Verdict
	- test Uimp control circuits (kV) :	-	N/A
	- test Uimp on open main contacts (equipment suitable for isolating) (kV) :	12,3 kV	P
a)	Application of test voltage		
	i) Between all terminals of the main circuit connected together (incl. control and auxiliary circuits connected to the main circuit) and the enclosure or mounting plate, with the contacts in all normal positions of operation.	Compliance	P
	ii) Between each pole of the main circuit and the other poles connected together and to the enclosure or mounting plate, with the contacts in all normal positions of operation.	Compliance	P
	iii) Between each control and auxiliary circuit not normally connected to the main circuit and: - the main circuit	Compliance	P
	- other circuits	-	N/A
	- exposed conductive parts	-	N/A
	- enclosure of mounting plate	-	N/A
	iv) equipment suitable for isolation	Compliance	P
	equipment not suitable for isolation		N/A
	- no unintentional disruptive discharge during the test's	Compliance	P
	Test of dielectric properties, dielectric withstand voltage (Uimp not indicated):		
	- rated insulation voltage (V) :	1000 V	P
	- main circuits, test voltage for 1 min (V)	2200 V	P
	- auxiliary circuits, test voltage for 1 min (V)	-	N/A
	- control circuits, test voltage for 1 min (V)	-	N/A
8.3.3.2.2	Application of test voltage		
1)	with circuit-breaker in the closed position		
	- between all live parts of all poles connected together and the frame of the circuit-breaker	Compliance	P
	- between each pole and all the other poles connected to the frame of the circuit-breaker	Compliance	P
2)	with the circuit-breaker in the open position and, additionally, in the tripped position, if any.		
	- between all live parts of all poles connected together and the frame of the circuit-breaker.	Compliance	P

TRF No. IEC60947_2F

ВАРНО С
ОРИГИНАЛА

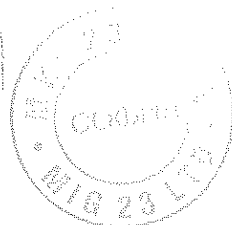

IEC 60947-2			
Clause	Requirement + Test	Result - Remark	Verdict
	- between the terminals of one side connected together and the terminals of the other side connected together.	Compliance	P
b)	Control and auxiliary circuits		
1)	- between all the control and auxiliary circuits which are not normally connected to the main circuit, connected together, and the frame of the circuit-breaker.	-	N/A
2)	- where appropriate, between each part of the control an auxiliary circuits which may be isolated from the other parts during normal operation and all the other parts connected together.	-	N/A
	No unintentional disruptive discharge during the tests	Compliance	P
8.3.3.2	For circuit-breaker suitable for isolation, the leakage current shall be measured through each pole with the contacts in the open position, at a test voltage of 1,1 Ue, and shall not exceed 0,5mA.	≤ 0,01 mA./ 759 V	P
8.3.3.3	Mechanical operation and operational performance capability		
8.3.3.3.2	Construction and mechanical operation		
a)	Construction		
	A withdrawable circuit-breaker shall be checked for the requirements stated in 7.1.1	-	N/A
	A circuit-breaker with stored energy operation shall be checked for compliance with 7.2.1.1.5, regarding the charge indicator and the direction of operation of manual energy storing	-	N/A
b)	Mechanical operation		
	A circuit-breaker with dependent power operation shall comply with the requirements stated in 7.2.1.1.3	-	N/A
	A circuit-breaker with dependent power operation shall operate with the operating mechanism charged to the minimum and maximum limits stated by the manufacturer	-	N/A
	A circuit-breaker with stored energy operation shall comply with the requirements stated in 7.2.1.5 with the auxiliary supply voltage at 85% and 110% of the rated control supply voltage.	-	N/A
	It shall also be verified that the moving contacts cannot be moved from the open position when the operating mechanism is charged to slightly below the full charge as evidenced by the indicating device	-	N/A

TRF No. IEC60947_2F

ВЕРНО С
ОПИСАНА

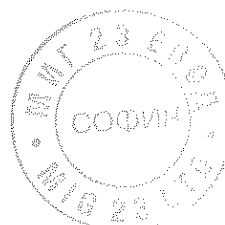

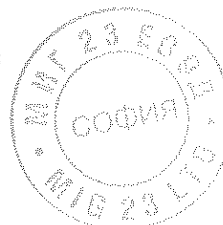

IEC 60947-2			
Clause	Requirement + Test	Result - Remark	Verdict
	For a trip-free circuit-breaker it shall not be possible to maintain the contacts in the touching or closed position when the tripping release is in the position to trip the circuit-breaker	-	N/A
	If the closing and opening times of a circuit-breaker are stated by the manufacturer, such times shall comply with the stated values	-	N/A
c)	Undervoltage releases		
	Undervoltage releases shall comply with the requirements of 7.2.1.3 of Part 1. For this purpose, the release shall be fitted to a circuit-breaker having the maximum current rating for which the release is suitable	-	N/A
i)	Drop out voltage		
	It shall be verified that the release operates to open the circuit-breaker between the voltage limits specified	-	N/A
	The voltage shall be reduced from rated voltage at a rate to reach 0 V in approximately 30 s	-	N/A
	The test for the lower limit is made without current in the main circuit and without previous heating of the release coil	-	N/A
	In the case of a release with a range of rated voltages, this test applies to the maximum voltage of the range	-	N/A
	The test for the upper limit is made starting from a constant temperature corresponding to the application of rated control supply voltage to the release and rated current in the main poles of the circuit-breaker	-	N/A
	This test may be combined with the temperature-rise test of 8.3.3.6	-	N/A
	In the case of a release with a range of rated voltages, this test is made at both the minimum and maximum rated control supply voltages	-	N/A
ii)	Test for limits of operation		
	Starting with the circuit-breaker open, at the temperature of the test room, and with the supply voltage at 30% rated maximum control supply voltage, it shall be verified that the circuit-breaker cannot be closed by the operation of the actuator	-	N/A
	When the supply voltage is raised to 85% of the minimum control supply voltage, it shall be verified that the circuit-breaker can be closed by the operation of the actuator	-	N/A

TRF No. IEC60947_2F

 ВЪРНО С
ОРИГИНАЛА

IEC 60947-2			
Clause	Requirement + Test	Result - Remark	Verdict
iii)	Performance under overvoltage conditions		
	With the circuit-breaker closed and without current in the main circuit, it shall be verified that the undervoltage release will withstand the application of 110% rated control supply voltage for 4 h without impairing its functions	-	N/A
d)	Shunt releases		
	Shunt releases shall comply with the requirements of 7.2.1.4 of Part 1. For this purpose, the release shall be fitted to a circuit-breaker having the maximum rated current for which the release is suitable	-	N/A
	It shall be verified that the release will operate to open the circuit-breaker at 70% rated control supply voltage when tested at an ambient temperature of + 55 °C ± 2 °C without current in the main poles of the circuit-breaker	-	N/A
	In the case of a release having a range of rated control supply voltages, the test voltage shall be 70% of the minimum rated control supply voltage	-	N/A
8.3.3.3.3	Operational performance capability without current.		
	Type designation or serial number	TS1600H 4P	
	Sample no:	S1-1	
	Rated current In (A)	1600 A	
	Rated operational voltage: Ue (V)	690 V	
	Rated control supply voltage of closing mechanism: Uc (V)		
	Rated control supply voltage of shunt releases: Uc (V)		
	Rated control supply voltage undervoltage releases: Uc (V)		
	Ambient temperature 10-40 °C :	25 °C	P
	Number of operating cycles per hour	20 Cycles per hour	P
	Number of cycles without current (total) (closing mechanism energized at the rated Uc)	-	N/A
	Number of cycles without current (without releases)	2500 Cycles	P
	Applied voltage: closing mechanism (V)	-	N/A
	10% of total cycles for circuit-breaker with fitted shunt release: (50% at the beginning- and 50% at the end of the test.) Energized at the rated Uc	-	N/A

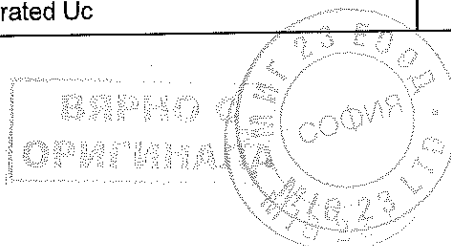
TRF No. IEC60947_2F



IEC 60947-2			
Clause	Requirement + Test	Result - Remark	Verdict
	Applied voltage: shunt releases (V)	-	N/A
	10% of total cycles for circuit-breaker with undervoltage releases: (50% at the beginning- and 50% at the end of the test.) Energized at the minimum rated U_c	-	N/A
	10 cycles without applied voltage at the undervoltage releases. (Shall not possible to close the circuit-breaker.)	-	N/A
	Applied voltage: undervoltage releases (V)	-	N/A
	Electrical components do not exceed the value indicated in tab. 7.	Compliance	P
8.3.3.3.4	Operational performance capability with current.		
	Rated current: I_n (A)	1600 A	
	Maximum rated operational voltage: U_e (V)	690 V	
	Conductor cross-sectional area (mm ²) :	500 mm ² X 2	P
	Number of operating cycles per hour	20 Cycles per hour	P
	Number of cycles with current (total) (closing mechanism energized at the rated U_c)	500 Cycles	P
	Applied voltage: closing mechanism (V)		P
	For circuit-breaker fitted with adjustable releases, test shall be made with the overload setting at maximum and short-circuit setting at minimum.	Compliance	P
	Conditions, make/break operations:		
	- test voltage $U/U_e = 1,0$ (V) L1: L2: L3:	L1: 691,8 V L2: 700,8 V L3: 708,3 V	P
	- test current $I/I_e = 1,0$ (A) L1: L2: L3:	L1: 1618 A L2: 1625 A L3: 1602 A	P
	- power factor/time constant:	0,73	P
	- frequency: (Hz)	60 Hz	P
	- on-time (ms):	1000 ms	P
	- off-time (s):	179 s	P
	Electrical components do not exceed the value indicated in tab. 7.	Compliance	P

TRF No. IEC60947_2F



IEC 60947-2			
Clause	Requirement + Test	Result - Remark	Verdict
8.3.3.3.5	Additional test of operational performance capability without current for withdrawable circuit-breaker.		
	Number of operations cycles : 100	-	N/A
	After test, the isolating contacts, withdrawable mechanism and interlocks shall be suitable for further service.	-	N/A
8.3.3.4	Overload performance		
	this test applies to circuit-breaker of rated current up to and including 630 A		
	Type designation or serial number		
	Sample no:		
	Rated current I_n (A)		
	Rated operational voltage: U_e (V)		
	Rated control supply voltage of closing mechanism: U_c (V)		
	Rated control supply voltage of shunt releases: U_c (V)		
	Rated control supply voltage undervoltage releases: U_c (V)		
	Ambient temperature 10-40 °C :	-	N/A
	Number of operating cycles per hour	-	N/A
	Maximum rated operational voltage: U_e (V)	-	N/A
	Number of operating cycles per hour	-	N/A
	Number of cycles with current (total) (closing mechanism energized at the rated U_c)	-	N/A
	Applied voltage: closing mechanism (V)	-	N/A
	For circuit-breaker fitted with adjustable releases, test shall be made with the overload/short-circuit settings at maximum.	-	N/A
	Conditions, overload operations:		
	- test voltage $U/U_e = 1,05$ (V) L1: L2: L3:	-	N/A
	- test current AC/DC: $I/I_n = 6,0/2,5$ (A) L1: L2: L3:	-	N/A
	- power factor/time constant:	-	N/A

TRF No. IEC60947_2F



IEC 60947-2			
Clause	Requirement + Test	Result - Remark	Verdict
	- Number of cycles manually opened: 9	-	N/A
	- Number of cycles automatically opened by an overload release: 3	-	N/A
	- frequency: (Hz)	-	N/A
	- on-time max 2s:	-	N/A
8.3.3.5	Verification of dielectric withstand		
	- equal to twice the rated operational voltage with a minimum of 1000 V for 5 seconds	1380 V	P
	- no breakdown or flashover	No	P
	For circuit-breaker suitable for isolation, the leakage current shall be measured through each pole with the contacts in the open position, at a test voltage of 1,1 U _e , and shall not exceed 2 mA.	≤ 0,02 mA / 759 V	P
8.3.3.6	Verification of temperature-rise		
****	- the values of temperature-rise do not exceed those specified in tab. 7.	See table S1-1 (4P)	P
	Temperature rise of main circuit terminals ≤ 80 K (K) :	≤ 69,1 K	P
	conductor cross-sectional area (mm ²) :	500 mm ² x 2	P
	test current I _e (A) :	1600 A	P
8.3.3.7	Verification of overload releases		
	Test current: 1.45 times the value of their current setting at the reference temperature: (A)	2320 A	P
	Conventional tripping time: <1h when I _n < 63A, <2h when I _n > 63 A	540 s	P
8.3.3.8	Verification of undervoltage and shunt releases		
	Circuit-breaker fitted with undervoltage releases. The release shall not operate at 70% of the minimum control supply voltage -	-	N/A
	and shall operate at 35% of the maximum control supply voltage.	-	N/A
	Circuit-breaker fitted with shunt releases. The release shall operate at 70% of the minimum rated control supply voltage. Test made at room temperature.	-	N/A
8.3.3.9	Verification of the main contact position for circuit-breakers for isolation		
	actuating force for opening (N)	216 N	—
	test force with blocked main contacts for 10 s (N) .:	648 N	—

TRF No. IEC60947_2F

ВЕРНО С
ОРИГИНАЛА

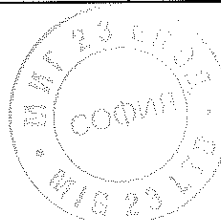

IEC 60947-2			
Clause	Requirement + Test	Result - Remark	Verdict
	Dependent power operation	-	N/A
	Supply voltage of 110% of rated voltage (V).....:	-	N/A
	Three attempts of 5 s to operate the equipment at intervals of 5 min.	-	N/A
	Independent power operation	-	N/A
	Three attempts to operate the equipment by the stored energy.	-	N/A
	Lock ability of driving mechanism in OFF-position at test force and blocked main contacts	-	N/A
	Position indicator does not show OFF-position after capture of test force at blocked main contacts	Compliance	P

ВІРНО С
ОРИГІНАЛ

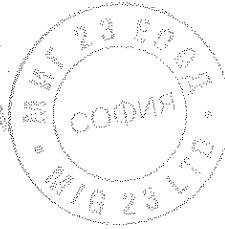

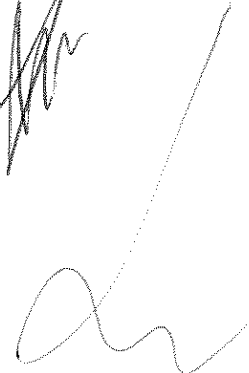



IEC 60947-2			
Clause	Requirement + Test	Result - Remark	Verdict
8.3.4	TEST SEQUENCE II (Ics):		
8.3.4.1	Test of rated service short-circuit breaking capacity		
	Test sequence of operation: O – t – CO – t – CO		
	Type designation or serial number	TS1600H 3P	
	Sample no:	S2-1 Rev	
	Rated current: In (A)	1600 A	
	Rated operational voltage: Ue (V)	240 V	
	Rated service short-circuit breaking capacity: (kA)	57 kA	
	Rated control supply voltage of closing mechanism: Uc (V)		
	Rated control supply voltage of shunt release: Uc (V)		
	For circuit-breaker fitted with adjustable releases, test shall be made with the current and time settings at maximum.	Compliance	P
	closing mechanism energized with 85% at the rated Uc (V)	-	N/A
	The circuit-breaker is mounted complete on its own support or an equivalent support.	Compliance	P
	Test made in free air:	Compliance	P
	Distances of the metallic screen's: (all sides)	Side : 73.5 mm, Front : 0 mm Top bottom : no screen	P
	The characteristics of the metallic screen:		
	- woven wire mesh	-	N/A
	- perforated metal	Compliance	P
	- expanded metal	-	N/A
	- ratio hole area/total area: 0,45-0,65	0,5	P
	- size of hole: <30mm ²	<30mm ²	P
	- finish: bare or conductive plating	Compliance	P
	Test made in specified individual enclosure: Details of these tests, including the dimensions of the enclosure:	-	N/A
	Fuse "F": copper wire: diameter 0,8 mm, 50 mm long	Compliance	P

TRF No. IEC60947_2F

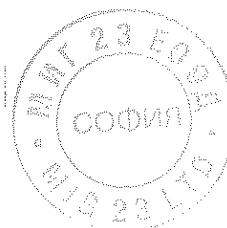
ВЪРНО С
ОРИГИНАЛА



IEC 60947-2			
Clause	Requirement + Test	Result - Remark	Verdict
	Circuit is earthed at: (load-star- or supply-star point)	Load-star point	P
	Conductor cross-sectional area (mm ²) :	2CX50X10 mm ²	P
	If terminals unmarked: line connected at: (underside/upside)	-	N/A
	Tightening torques: (Nm)	50 Nm	P
	Test sequence of operation: O – t – CO – t – CO	Compliance	P
	- test voltage U/Ue = 1,05 (V) L1: L2: L3:	L1: 253,6 V L2: 253,0 V L3: 254,1 V	P
	- r.m.s. test current AC/DC: (A)..... L1: L2: L3:	L1: 57,7 kA L2: 57,6 kA L3: 57,5 kA	P
	power factor/time constant :	0,2	P
	- Factor "n"	2,27	P
	- peak test current (A) :	131,1 kA	P
	Test sequence "O"		
	- max. let-through current: (kA _{peak}) L1: L2: L3:	L1: 121,5 kA L2: 93,1 kA L3: 87,0 kA	P
	- Joule integral I ² dt (A ² s) L1: L2: L3:	L1: 70,1 MA ² s L2: 43,0 MA ² s L3: 31,8 MA ² s	P
	Pause, t: (min)	3	P
	Test sequence "CO"		
	- max. let-through current: (kA _{peak}) L1: L2: L3:	L1: 67,5 kA L2: 105,0 kA L3: 116,7 kA	P
	- Joule integral I ² dt (A ² s) L1: L2: L3:	L1: 28,6 MA ² s L2: 49,3 MA ² s L3: 57,0 MA ² s	P
	Pause, t: (min)	3	P
	Test sequence "CO"		
	- max. let-through current: (kA _{peak}) L1: L2: L3:	L1: 100,8 kA L2: 80,6 kA L3: 115,1 kA	P

TRF No. IEC60947_2F

ВАРНО С
ОРИГИНАЛА

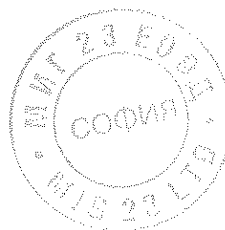

IEC 60947-2			
Clause	Requirement + Test	Result - Remark	Verdict
	- Joule integral I ² dt (A ² s) L1: L2: L3:	L1: 51,9 MA ² s L2: 30,9 MA ² s L3: 64,1 MA ² s	P
	Melting of the fusible element	Compliance	P
	Holes in the PE-sheet for test sequence "O"	-	N/A
	Cracks observed	Compliance	P
8.3.4.2	Operational performance capability with current.		
	Rated current: I _n (A)	1600 A	
	Maximum rated operational voltage: U _e (V)	240 V	
	Conductor cross-sectional area (mm ²) :	500 mm ² X 2	
	Number of operating cycles per hour	20 Cycles per hour	P
	Number (5% of the number given in column 4, tab. 8) of cycles with current (total) (closing mechanism energized at the rated U _c)	25 Cycles	P
	Applied voltage: closing mechanism (V)	-	N/A
	For circuit-breaker fitted with adjustable releases, test shall be made with the overload setting at maximum and short-circuit setting at minimum.	Compliance	P
	Conditions, make/break operations:		
	- test voltage U/U _e = 1,0 (V) L1: L2: L3:	L1: 243,5 V L2: 250,5 V L3: 251,5 V	P
	- test current I/I _e = 1,0 (A) L1: L2: L3:	L1: 1604 A L2: 1618 A L3: 1606 A	P
	- power factor/time constant:	0,71	P
	- frequency: (Hz)	60 Hz	P
	- on-time (ms):	1000 ms	P
	- off-time (s):	179 s	P
8.3.4.3	Verification of dielectric withstand		
	- equal to twice the rated operational voltage with a minimum of 1000 V	1000 V	P
	- no breakdown or flashover	No	P
	- the leaking current for circuit-breaker suitable for isolation: (<2mA / 1.1 U _e)	≤ 1,14 mA / 264 V	P

TRF No. IEC60947_2F

ВЕРНО С
ОРИГИНАЛА

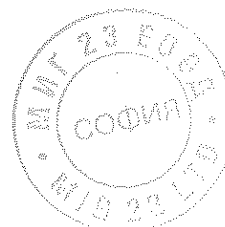

IEC 60947-2			
Clause	Requirement + Test	Result - Remark	Verdict
8.3.4.4	Verification of temperature-rise		
	- the values of temperature-rise do not exceed those specified in tab. 7.	See table S2-1R (3P)	P
	Temperature rise of main circuit terminals. ≤ 80 K (K) :	≤ 75,3 K	P
	conductor cross-sectional area (mm ²) :	500 mm ² x 2	P
	test current I _e (A) :	1600 A	P
8.3.4.5	Verification of overload releases		
	Test current: 1.45 times the value of their current setting at the reference temperature: (A)	2320 A	P
	Conventional tripping time: <1h when I _n < 63A, <2h when I _n > 63 A	535 s	P

8.3.4	TEST SEQUENCE II (Ics):		
8.3.4.1	Test of rated service short-circuit breaking capacity		
	Test sequence of operation: O – t – CO – t – CO		
	Type designation or serial number	TS1600H 3P	
	Sample no:	S2-2	
	Rated current: I _n (A)	630 A	
	Rated operational voltage: U _e (V)	240 V	
	Rated service short-circuit breaking capacity: (kA)	57 kA	
	Rated control supply voltage of closing mechanism: U _c (V)		
	Rated control supply voltage of shunt release: U _c (V)		
	For circuit-breaker fitted with adjustable releases, test shall be made with the current and time settings at maximum.	Compliance	P
	closing mechanism energized with 85% at the rated U _c : (V)	-	N/A
	The circuit-breaker is mounted complete on its own support or an equivalent support.	Compliance	P
	Test made in free air:	Compliance	P
	Distances of the metallic screen's: (all sides)	Side : 73.5 mm, Front : 0 mm Top bottom : no screen	P

TRF No. IEC60947_2F

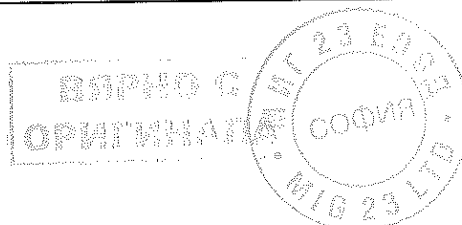

IEC 60947-2			
Clause	Requirement + Test	Result - Remark	Verdict
	The characteristics of the metallic screen:		
	- woven wire mesh	-	N/A
	- perforated metal	Compliance	P
	- expanded metal	-	N/A
	- ratio hole area/total area: 0,45-0,65	0,5	P
	- size of hole: <30mm ²	< 30mm ²	P
	- finish: bare or conductive plating	Compliance	P
	Test made in specified individual enclosure: Details of these tests, including the dimensions of the enclosure:	-	N/A
	Fuse "F": copper wire: diameter 0,8 mm, 50 mm long	Compliance	P
	Circuit is earthed at: (load-star- or supply-star point)	Load-star point	P
	Conductor cross-sectional area (mm ²) :	2CX40X5 mm ²	P
	If terminals unmarked: line connected at: (underside/upside)	-	N/A
	Tightening torques: (Nm)	50 Nm	P
	Test sequence of operation: O – t – CO – t – CO	Compliance	P
	- test voltage U/Ue = 1,05 (V) L1: L2: L3:	L1: 253,7 V L2: 252,8 V L3: 254,0 V	P
	- r.m.s. test current AC/DC: (A)..... L1: L2: L3:	L1: 57,7 kA L2: 57,6 kA L3: 57,5 kA	P
	power factor/time constant :	0,20	P
	- Factor "n"	2,27	P
	- peak test current (A) :	131,1 kA	P
	Test sequence "O"		
	- max. let-through current: (kA _{peak}) L1: L2: L3:	L1: 123,2 kA L2: 93,1 kA L3: 91,3 kA	P
	- Joule integral I ² dt (A ² s) L1: L2: L3:	L1: 73,9 MA ² s L2: 44,6 MA ² s L3: 36,2 MA ² s	P
	Pause, t: (min)	4	P

TRF No. IEC60947_2F

ВАРНО С
ОРИГИНАЛ

МНТ 23 ЕР ВА
СОФИЯ
МНТ 23 ЕР ВА



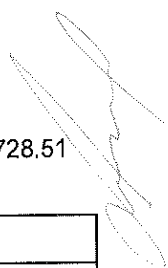

IEC 60947-2			
Clause	Requirement + Test	Result - Remark	Verdict
	Test sequence "CO"		
	- max. let-through current: (kA _{peak}) L1: L2: L3:	L1: 75,1 kA L2: 110,2 kA L3: 111,4 kA	P
	- Joule integral I ² dt (A ² s) L1: L2: L3:	L1: 32,8 MA ² s L2: 59,6 MA ² s L3: 65,0 MA ² s	P
	Pause, t: (min)	3	P
	Test sequence "CO"		
	- max. let-through current: (kA _{peak}) L1: L2: L3:	L1: 112,4 kA L2: 78,2 kA L3: 97,5 kA	P
	- Joule integral I ² dt (A ² s) L1: L2: L3:	L1: 66,4 MA ² s L2: 38,0 MA ² s L3: 43,7 MA ² s	P
	Melting of the fusible element	Compliance	P
	Holes in the PE-sheet for test sequence "O"	-	N/A
	Cracks observed	Compliance	P
8.3.4.2	Operational performance capability with current.		
	Rated current: I _n (A)		
	Maximum rated operational voltage: U _e (V)		
	Conductor cross-sectional area (mm ²) :		
	Number of operating cycles per hour	-	N/A
	Number (5% of the number given in column 4, tab. 8) of cycles with current (total) (closing mechanism energized at the rated U _c)	-	N/A
	Applied voltage: closing mechanism (V)	-	N/A
	For circuit-breaker fitted with adjustable releases, test shall be made with the overload setting at maximum and short-circuit setting at minimum.	-	N/A
	Conditions, make/break operations:		
	- test voltage U/U _e = 1,0 (V) L1: L2: L3:	-	N/A
	- test current I/I _e = 1,0 (A) L1: L2: L3:	-	N/A

TRF No. IEC60947_2F

ВАРНО С
ОРИГИНАЛО

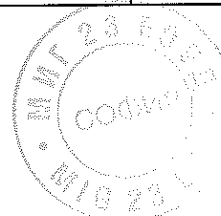
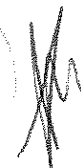



IEC 60947-2			
Clause	Requirement + Test	Result - Remark	Verdict
	- power factor/time constant:	-	N/A
	- frequency: (Hz)	-	N/A
	- on-time (ms):	-	N/A
	- off-time (s):	-	N/A
8.3.4.3	Verification of dielectric withstand		
	- equal to twice the rated operational voltage with a minimum of 1000 V	1000 V	P
	- no breakdown or flashover	No	P
	- the leaking current for circuit-breaker suitable for isolation: (<2mA / 1.1 Ue)	≤ 0,77 mA / 264 V	P
8.3.4.4	Verification of temperature-rise		
	- the values of temperature-rise do not exceed those specified in tab. 7.	-	N/A
	Temperature rise of main circuit terminals. ≤ 80 K (K) :	-	N/A
	conductor cross-sectional area (mm ²) :	-	N/A
	test current I _e (A) :	-	N/A
8.3.4.5	Verification of overload releases		
	Test current: 1.45 times the value of their current setting at the reference temperature: (A)	913,5 A	P
	Conventional tripping time: <1h when I _n < 63A, <2h when I _n > 63 A	517 s	P

8.3.4	TEST SEQUENCE II (Ics):		
8.3.4.1	Test of rated service short-circuit breaking capacity		
	Test sequence of operation: O – t – CO – t – GO		
	Type designation or serial number	TS1600H 3P	
	Sample no:	S2-3	
	Rated current: I _n (A)	1600 A	
	Rated operational voltage: U _e (V)	460 V	
	Rated service short-circuit breaking capacity: (kA)	50 kA	
	Rated control supply voltage of closing mechanism: U _c (V)		
	Rated control supply voltage of shunt release: U _c (V)		

TRF No. IEC60947_2F

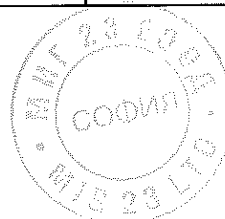
ВАРНО С
ОРИГИНАЛА



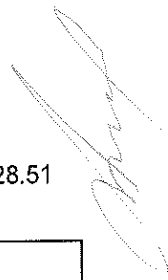

IEC 60947-2			
Clause	Requirement + Test	Result - Remark	Verdict
	For circuit-breaker fitted with adjustable releases, test shall be made with the current and time settings at maximum.	Compliance	P
	closing mechanism energized with 85% at the rated Uc: (V)	-	N/A
	The circuit-breaker is mounted complete on its own support or an equivalent support.	Compliance	P
	Test made in free air:	Compliance	P
	Distances of the metallic screen's: (all sides)	Side : 73.5 mm, Front : 0 mm Top bottom : no screen	P
	The characteristics of the metallic screen:		
	- woven wire mesh	-	N/A
	- perforated metal	Compliance	P
	- expanded metal	-	N/A
	- ratio hole area/total area: 0,45-0,65	0,5	P
	- size of hole: <30mm ²	< 30mm ²	P
	- finish: bare or conductive plating	Compliance	P
	Test made in specified individual enclosure: Details of these tests, including the dimensions of the enclosure:	-	N/A
	Fuse "F": copper wire: diameter 0,8 mm, 50 mm long	Compliance	P
	Circuit is earthed at: (load-star- or supply-star point)	Load-star point	P
	Conductor cross-sectional area (mm ²) :	2CX50X10 mm ²	P
	If terminals unmarked: line connected at: (underside/upside)	-	N/A
	Tightening torques: (Nm).	50 Nm	P
	Test sequence of operation: Q – t – CO – t – CO	Compliance	P
	- test voltage U/U _e = 1,05 (V) L1: L2: L3:	L1: 486,2 V L2: 488,7 V L3: 484,7 V	P
	- r.m.s. test current AC/DC: (A)..... L1: L2: L3:	L1: 50,9 kA L2: 50,3 kA L3: 50,5 kA	P
	power factor/time constant :	0,23	P
	- Factor "n"	2,17	P

TRF No. IEC60947_2F

ВЕРНО С
ОРИГИНАЛА

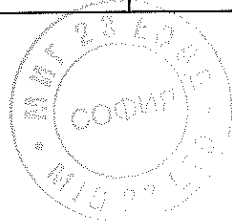

IEC 60947-2			
Clause	Requirement + Test	Result - Remark	Verdict
	- peak test current (A) :	110,9 kA	P
	Test sequence "O"		
	- max. let-through current: (kA _{peak}) L1: L2: L3:	L1: 108,9 kA L2: 82,4 kA L3: 86,2 kA	P
	- Joule integral I ² dt (A ² s) L1: L2: L3:	L1: 62,0 MA ² s L2: 38,3 MA ² s L3: 35,3 MA ² s	P
	Pause, t: (min)	5	P
	Test sequence "CO"		
	- max. let-through current: (kA _{peak}) L1: L2: L3:	L1: 86,5 kA L2: 83,1 kA L3: 106,8 kA	P
	- Joule integral I ² dt (A ² s) L1: L2: L3:	L1: 45,8 MA ² s L2: 37,9 MA ² s L3: 64,3 MA ² s	P
	Pause, t: (min)	3	P
	Test sequence "CO"		
	- max. let-through current: (kA _{peak}) L1: L2: L3:	L1: 73,8 kA L2: 102,3 kA L3: 98,6 kA	P
	- Joule integral I ² dt (A ² s) L1: L2: L3:	L1: 31,5 MA ² s L2: 54,7 MA ² s L3: 54,1 MA ² s	P
	Melting of the fusible element	Compliance	P
	Holes in the PE-sheet for test sequence "O"	-	N/A
	Cracks observed	Compliance	P
8.3.4.2	Operational performance capability with current.		
	Rated current: I _n (A)	1600 A	
	Maximum rated operational voltage: U _e (V)	460 V	
	Conductor cross-sectional area (mm ²) :	500 mm ² X 2	
	Number of operating cycles per hour	20 Cycles per hour	P
	Number (5% of the number given in column 4, tab. 8) of cycles with current (total) (closing mechanism energized at the rated U _c)	25 Cycles	P
	Applied voltage: closing mechanism (V)	-	N/A

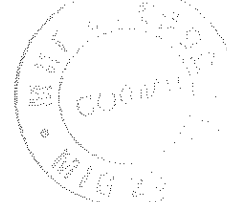

TRF No. IEC60947_2F

ВАРНО С
ОРИГИНАЛА

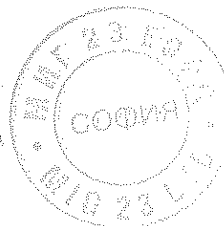

IEC 60947-2			
Clause	Requirement + Test	Result - Remark	Verdict
	For circuit-breaker fitted with adjustable releases, test shall be made with the overload setting at maximum and short-circuit setting at minimum.	-	N/A
	Conditions, make/break operations:		
	- test voltage $U/U_e = 1,0$ (V) L1: L2: L3:	L1: 472,0 V L2: 474,8 V L3: 476,8 V	P
	- test current $I/I_e = 1,0$ (A)..... L1: L2: L3:	L1: 1600 A L2: 1622 A L3: 1610 A	P
	- power factor/time constant:	0,70	P
	- frequency: (Hz)	60 Hz	P
	- on-time (ms):	1000 ms	P
	- off-time (s):	179 s	P
8.3.4.3	Verification of dielectric withstand		
	- equal to twice the rated operational voltage with a minimum of 1000 V	1000 V	P
	- no breakdown or flashover	No	P
	- the leaking current for circuit-breaker suitable for isolation: ($<2\text{mA} / 1.1 U_e$)	$\leq 0,58 \text{ mA} / 506 \text{ V}$	P
8.3.4.4	Verification of temperature-rise		
	- the values of temperature-rise do not exceed those specified in tab. 7.	See table S2-3 (3P)	P
	Temperature rise of main circuit terminals. $\leq 80 \text{ K}$ (K) :	$\leq 78,4 \text{ K}$	P
	conductor cross-sectional area () :	$500 \text{ mm}^2 \times 2$	P
	test current I_e (A) :	1600 A	P
8.3.4.5	Verification of overload releases		
	Test current: 1.45 times the value of their current setting at the reference temperature: (A)	2320 A	P
	Conventional tripping time: $<1\text{h}$ when $I_n < 63\text{A}$, $<2\text{h}$ when $I_n > 63 \text{ A}$	532 s	P

ВЯРНО С
ОРИГИНАЛА



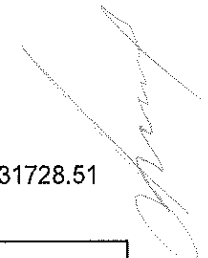



IEC 60947-2			
Clause	Requirement + Test	Result - Remark	Verdict
8.3.4	TEST SEQUENCE II (Ics):		
8.3.4.1	Test of rated service short-circuit breaking capacity		
	Test sequence of operation: O – t – CO – t – CO		
	Type designation or serial number	TS1600H 3P	
	Sample no:	S2-4 Rev	
	Rated current: In (A)	1600 A	
	Rated operational voltage: Ue (V)	690 V	
	Rated service short-circuit breaking capacity: (kA)	35 kA	
	Rated control supply voltage of closing mechanism: Uc (V)		
	Rated control supply voltage of shunt release: Uc (V)		
	For circuit-breaker fitted with adjustable releases, test shall be made with the current and time settings at maximum.	Compliance	P
	closing mechanism energized with 85% at the rated Uc: (V)	-	N/A
	The circuit-breaker is mounted complete on its own support or an equivalent support.	Compliance	P
	Test made in free air:	Compliance	P
	Distances of the metallic screen's: (all sides)	Side : 73.5 mm, Front : 0 mm Top bottom : no screen	P
	The characteristics of the metallic screen:		
	- woven wire mesh	-	N/A
	- perforated metal	Compliance	P
	- expanded metal	-	N/A
	- ratio hole area/total area: 0,45-0,65	0,5	P
	- size of hole: <30mm ²	< 30mm ²	P
	- finish: bare or conductive plating	Compliance	P
	Test made in specified individual enclosure: Details of these tests, including the dimensions of the enclosure:	-	N/A
	Fuse "F": copper wire: diameter 0,8 mm, 50 mm long	Compliance	P
	Circuit is earthed at: (load-star- or supply-star point)	Load-star point	P

TRF No. IEC60947_2F

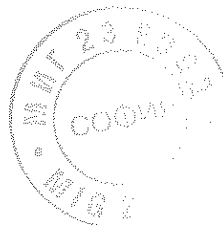
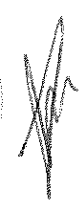
ВАРНО С
ОРИГИНАЛА

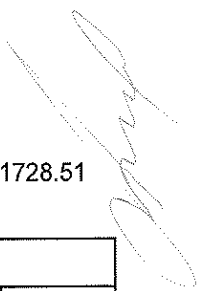

IEC 60947-2			
Clause	Requirement + Test	Result - Remark	Verdict
	Conductor cross-sectional area (mm ²) :	2CX50X10 mm ²	P
	If terminals unmarked: line connected at: (underside/upside)	-	N/A
	Tightening torques: (Nm)	50 Nm	P
	Test sequence of operation: O – t – CO – t – CO	Compliance	P
	- test voltage U/U _e = 1,05 (V) L1: L2: L3:	L1: 734,9 V L2: 735,7 V L3: 733,0 V	P
	- r.m.s. test current AC/DC: (A)..... L1: L2: L3:	L1: 35,1 kA L2: 35,0 kA L3: 35,1 kA	P
	power factor/time constant :	0,24	P
	- Factor "n"	2,17	P
	- peak test current (A) :	76,3 kA	P
	Test sequence "O"		
	- max. let-through current: (kA _{peak}) L1: L2: L3:	L1: 74,5 kA L2: 58,3 kA L3: 63,2 kA	P
	- Joule integral I ² dt (A ² s) L1: L2: L3:	L1: 31,5 MA ² s L2: 21,6 MA ² s L3: 20,4 MA ² s	P
	Pause, t: (min)	5	P
	Test sequence "CO"		
	- max. let-through current: (kA _{peak}) L1: L2: L3:	L1: 56,9 kA L2: 74,7 kA L3: 65,9 kA	P
	- Joule integral I ² dt (A ² s) L1: L2: L3:	L1: 17,9 MA ² s L2: 30,9 MA ² s L3: 24,7 MA ² s	P
	Pause, t: (min)	3	P
	Test sequence "CO"		
	- max. let-through current: (kA _{peak}) L1: L2: L3:	L1: 62,8 kA L2: 59,0 kA L3: 74,5 kA	P

TRF No. IEC60947_2F

БАРНО С
ОПРЕДЕЛЕНИЕ

СЕРТИФИКАТ
23 ЛТЕ



IEC 60947-2			
Clause	Requirement + Test	Result - Remark	Verdict
	- Joule integral I ² dt (A ² s) L1: L2: L3:	L1: 25,2 MA ² s L2: 20,3 MA ² s L3: 32,0 MA ² s	P
	Melting of the fusible element	Compliance	P
	Holes in the PE-sheet for test sequence "O"	-	N/A
	Cracks observed	Compliance	P
8.3.4.2	Operational performance capability with current.		
	Rated current: I _n (A)	1600 A	
	Maximum rated operational voltage: U _e (V)	690 V	
	Conductor cross-sectional area (mm ²) :	500 mm ² X 2	
	Number of operating cycles per hour	20 Cycles per hour	P
	Number (5% of the number given in column 4, tab. 8) of cycles with current (total) (closing mechanism energized at the rated U _c)	25 Cycles	P
	Applied voltage: closing mechanism (V)	-	N/A
	For circuit-breaker fitted with adjustable releases, test shall be made with the overload setting at maximum and short-circuit setting at minimum.	-	N/A
	Conditions, make/break operations:		
	- test voltage U/U _e = 1,0 (V) L1: L2: L3:	L1: 716,5 V L2: 719,8 V L3: 716,0 V	P
	- test current I/I _e = 1,0 (A) L1: L2: L3:	L1: 1622 A L2: 1622 A L3: 1624 A	P
	- power factor/time constant:	0,73	P
	- frequency: (Hz)	60 Hz	P
	- on-time (ms):	1000 ms	P
	- off-time (s):	179 s	P
8.3.4.3	Verification of dielectric withstand		
	- equal to twice the rated operational voltage with a minimum of 1000 V	1380 V	P
	- no breakdown or flashover	No	P
	- the leaking current for circuit-breaker suitable for isolation: (<2mA / 1.1/U _e)	≤0,07 mA / 759 V	P

TRF No. IEC60947_2F

ВЕРНО С
ОРИГИНАЛА

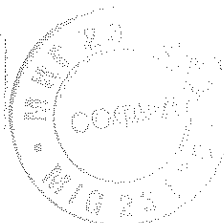

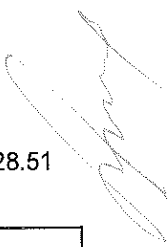
IEC 60947-2			
Clause	Requirement + Test	Result - Remark	Verdict
8.3.4.4	Verification of temperature-rise		
	- the values of temperature-rise do not exceed those specified in tab. 7.	See table S2-4R (3P)	
	Temperature rise of main circuit terminals. ≤ 80 K (K) :	≤ 78,9 K	P
	conductor cross-sectional area (mm ²) :	500 mm ² x 2	P
	test current I _e (A) :	1600 A	P
8.3.4.5	Verification of overload releases		
	Test current: 1.45 times the value of their current setting at the reference temperature: (A)	2320 A	P
	Conventional tripping time: <1h when I _n < 63A, <2h when I _n > 63 A	537 s	P

8.3.4	TEST SEQUENCE II/III (I _{cs} =I _{cu}):	N/A
-------	---	-----

8.3.5	TEST SEQUENCE III (I _{cu})	
	Rated ultimate short-circuit breaking	
	Except where the combined test sequence applies, this test sequence applies to circuit-breaker of utilization category A and to circuit-breaker of utilization B having a rated ultimate short-circuit breaking capacity higher than the rated short-time withstand current.	
	For circuit-breakers of utilization B having a rated short-time withstand current equal to their rated ultimate short-circuit breaking capacity, this test sequence need not be made, since, in this case, the ultimate short-circuit breaking capacity, is verified when carrying out test sequence IV.	
	For integrally fused circuit-breakers, test sequence V applies in place of this sequence.	
	Type designation or serial number	TS1600H 3P
	Sample no:	S3-1
	Rated current: I _n (A)	1600 A
	Rated operational voltage: U _e (V)	240 V
	Rated ultimate short-circuit breaking capacity: (kA)	75 kA
	Rated control supply voltage of closing mechanism: U _c (V)	

TRF No. IEC60947_2F

ВЕРНО С
ОРИГИНАЛА

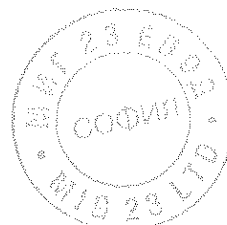

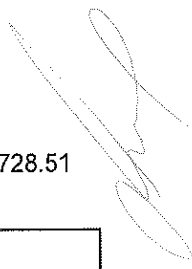



IEC 60947-2			
Clause	Requirement + Test	Result - Remark	Verdict
	Rated control supply voltage of shunt release: Uc (V)		
	This test sequence need not be made when Icu = Ics		
8.3.5.1	The operation of overload releases shall be verified at twice the value of their current setting on each pole separately.		
	The operating time shall not exceed the max. value stated by the manufacturer for twice the current setting at the reference temperature, on a pole singly.		
	Time specified by the manufacturer:	152~317 s	P
	- Operation time: (s) L1: L2: L3: N :	216 s 204 s 220 s	P
8.3.5.2	Test of rated ultimate short-circuit breaking capacity		
	The test sequence of operations is O – t – CO		
	For circuit-breaker fitted with adjustable releases, test shall be made with the current and time settings at maximum.	Compliance	P
	closing mechanism energized with 85% at the rated Uc: (V)	-	N/A
	The circuit-breaker is mounted complete on its own support or an equivalent support.	Compliance	P
	Test made in free air:	Compliance	P
	Distances of the metallic screen's: (all sides)	Side : 73.5 mm, Front : 0 mm Top bottom : no screen	P
	The characteristics of the metallic screen:		
	- woven wire mesh	-	N/A
	- perforated metal	Compliance	P
	- expanded metal	-	N/A
	- ratio hole area/total area: 0,45-0,65	0,5	P
	- size of hole: <30mm ²	< 30mm ²	P
	- finish: bare or conductive plating	Compliance	P
	Test made in specified individual enclosure: Details of these tests, including the dimensions of the enclosure:	-	N/A
	Fuse "F": copper wire: diameter 0,8 mm, 50 mm long	Compliance	P
	Circuit is earthed at: (load-star- or supply-star point)	Load-star point	P

TRF No. IEC60947_2F

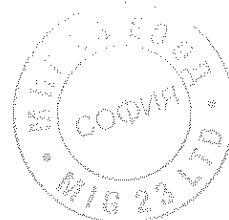
ВЕРНО С
ОРИГИНАЛА

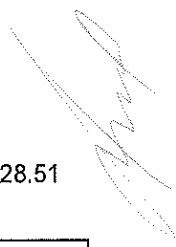



IEC 60947-2			
Clause	Requirement + Test	Result - Remark	Verdict
	Conductor cross-sectional area (mm ²) :	2CX50X10 mm ²	P
	If terminals unmarked: line connected at: (underside/upside)	-	N/A
	Tightening, torques: (Nm)	50 Nm	P
	Test sequence of operation: O – t – CO	Compliance	P
	- test voltage U/U _e = 1,05 (V) L1: L2: L3:	L1: 253,6 V L2: 253,6 V L3: 253,7 V	P
	- r.m.s. test current AC/DC: (A)..... L1: L2: L3:	L1: 75,9 kA L2: 76,3 kA L3: 74,8 kA	P
	power factor/time constant :	0,20	P
	- Factor "n"	2,27	P
	- peak test current (A _{max}) :	172,9 kA	
	Test sequence "O"		
	- max. let-through current: (kA _{peak}) L1: L2: L3:	L1: 126,1 kA L2: 122,8 kA L3: 109,8 kA	P
	- Joule integral I ² dt (A ² s) L1: L2: L3:	L1: 92,5 MA ² s L2: 71,7 MA ² s L3: 50,5 MA ² s	P
	Pause, t: (min)	4	P
	Test sequence "CO"		
	- max. let-through current: (kA _{peak}) L1: L2: L3:	L1: 126,1 kA L2: 110,1 kA L3: 111,4 kA	P
	- Joule integral I ² dt (A ² s) L1: L2: L3:	L1: 92,0 MA ² s L2: 64,0 MA ² s L3: 53,9 MA ² s	P
	Melting of the fusible element	Compliance	P
	Holes in the PE-sheet for test sequence "O"	-	N/A
	Cracks observed	Compliance	P
8.3.5.3	Verification of dielectric withstand		
	- equal to twice the rated operational voltage with a minimum of 1000 V for 5 seconds	1000 V	P
	- no breakdown or flashover	No	P

TRF No. IEC60947_2F

ВЯРНО С
ОРИГИНАЛА

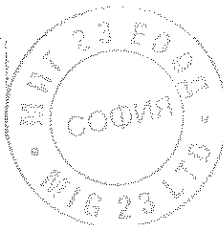

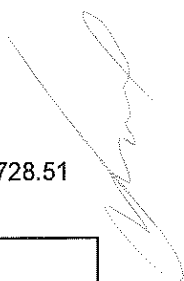
IEC 60947-2			
Clause	Requirement + Test	Result - Remark	Verdict
	- the leaking current for circuit-breaker suitable for isolation: (<6mA / 1,1 Ue)	≤ 0,1 mA / 264 V	P
8.3.5.4	Verification of overload releases		
	The operation of overload releases shall be verified at 2,5 times the value of their current setting on each pole separately.		
	The operating time shall not exceed the max. value stated by the manufacturer for twice the current setting at the reference temperature, on a pole singly.		
	Time specified by the manufacturer:	92~182 s	P
	- Operation time: (s) L1: L2: L3: N :	123 s 122 s 129 s	P

8.3.5	TEST SEQUENCE III (Icu)		
	Rated ultimate short-circuit breaking		
	Except where the combined test sequence applies, this test sequence applies to circuit-breaker of utilization category A and to circuit-breaker of utilization B having a rated ultimate short-circuit breaking capacity higher than the rated short-time withstand current.		
	For circuit-breakers of utilization B having a rated short-time withstand current equal to their rated ultimate short-circuit breaking capacity, this test sequence need not be made, since, in this case, the ultimate short-circuit breaking capacity, is verified when carrying out test sequence IV.		
	For integrally fused circuit-breakers, test sequence V applies in place of this sequence.		
	Type designation or serial number	TS1600H 3P	
	Sample no:	S3-2	
	Rated current: In (A)	630 A	
	Rated operational voltage: Ue (V)	240 V	
	Rated ultimate short-circuit breaking capacity: (kA)	75 kA	
	Rated control supply voltage of closing mechanism: Uc (V)		
	Rated control supply voltage of shunt release: Uc (V)		

TRF No. IEC60947_2F

ВАРНО С
ОРИГИНАЛА

МИГ 23 LTD
СОФИЯ



IEC 60947-2			
Clause	Requirement + Test	Result - Remark	Verdict
	This test sequence need not be made when Icu = Ics		
8.3.5.1	The operation of overload releases shall be verified at twice the value of their current setting on each pole separately.		
	The operating time shall not exceed the max. value stated by the manufacturer for twice the current setting at the reference temperature, on a pole singly.		
	Time specified by the manufacturer:	152~317 s	P
	- Operation time: (s) L1:	218 s	P
 L2:	212 s	
 L3:	214 s	
 N :		
8.3.5.2	Test of rated ultimate short-circuit breaking capacity		
	The test sequence of operations is O – t – CO		
	For circuit-breaker fitted with adjustable releases, test shall be made with the current and time settings at maximum.	Compliance	P
	closing mechanism energized with 85% at the rated Uc: (V)	-	N/A
	The circuit-breaker is mounted complete on its own support or an equivalent support.	Compliance	P
	Test made in free air:	Compliance	P
	Distances of the metallic screen's: (all sides)	Side : 73.5 mm, Front : 0 mm Top bottom : no screen	P
	The characteristics of the metallic screen:		
	- woven wire mesh	-	N/A
	- perforated metal	Compliance	P
	- expanded metal	-	N/A
	- ratio hole area/total area: 0,45-0,65	0,5	P
	- size of hole: <30mm ²	< 30mm ²	P
	- finish: bare or conductive plating	Compliance	P
	Test made in specified individual enclosure: Details of these tests, including the dimensions of the enclosure:	-	N/A
	Fuse "F": copper wire: diameter 0,8 mm, 50 mm long	Compliance	P
	Circuit is earthed at: (load-star- or supply-star point)	Load-star point	P
	Conductor cross-sectional area (mm ²) :	2CX40X5 mm ²	P

TRF No. IEC60947_2F

ВЕРНО С
ОРИГИНАЛА

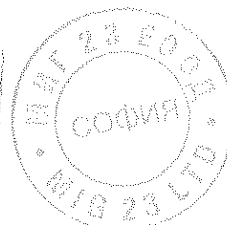

IEC 60947-2			
Clause	Requirement + Test	Result - Remark	Verdict
	If terminals unmarked: line connected at: (underside/upside)	-	N/A
	Tightening, torques: (Nm)	50 Nm	P
	Test sequence of operation: O – t – CO	Compliance	P
	- test voltage $U/U_e = 1,05$ (V) L1: L2: L3:	L1: 253,8 V L2: 253,2 V L3: 254,1 V	P
	- r.m.s. test current AC/DC: (A)..... L1: L2: L3:	L1: 75,9 kA L2: 76,3 kA L3: 74,8 kA	P
	power factor/time constant :	0,20	P
	- Factor "n"	2,28	
	- peak test current (I_{max}) :	172,9 kA	
	Test sequence "O"		
	- max. let-through current: (kA_{peak}) L1: L2: L3:	L1: 142,5 kA L2: 120,7 kA L3: 108,0 kA	P
	- Joule integral I^2dt (A^2s) L1: L2: L3:	L1: 98,0 MA^2s L2: 68,4 MA^2s L3: 48,9 MA^2s	P
	Pause, t: (min)	6	P
	Test sequence "CO"		
	- max. let-through current: (kA_{peak}) L1: L2: L3:	L1: 133,3 kA L2: 89,6 kA L3: 127,9 kA	P
	- Joule integral I^2dt (A^2s) L1: L2: L3:	L1: 85,3 MA^2s L2: 46,1 MA^2s L3: 75,1 MA^2s	P
	Melting of the fusible element	Compliance	P
	Holes in the PE-sheet for test sequence "O"	-	N/A
	Cracks observed	Compliance	P
8.3.5.3	Verification of dielectric withstand		
	- equal to twice the rated operational voltage with a minimum of 1000 V for 5 seconds	1000 V	P
	- no breakdown or flashover	No	P

TRF No. IEC60947_2F

ВЕРНО С
ОРИГИНАЛА

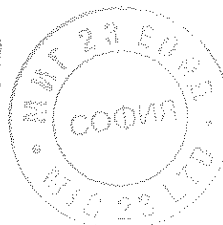

IEC 60947-2			
Clause	Requirement + Test	Result - Remark	Verdict
	- the leaking current for circuit-breaker suitable for isolation: (<6mA / 1,1 Ue)	≤ 1,31 mA / 264 V	P
8.3.5.4	Verification of overload releases		
	The operation of overload releases shall be verified at 2,5 times the value of their current setting on each pole separately.		
	The operating time shall not exceed the max. value stated by the manufacturer for twice the current setting at the reference temperature, on a pole singly.		
	Time specified by the manufacturer:	92~182 s	P
	- Operation time: (s) L1: L2: L3: N :	128 s 125 s 126 s	P

8.3.5	TEST SEQUENCE III (Icu)		
	Rated ultimate short-circuit breaking		
	Except where the combined test sequence applies, this test sequence applies to circuit-breaker of utilization category A and to circuit-breaker of utilization B having a rated ultimate short-circuit breaking capacity higher than the rated short-time withstand current.		
	For circuit-breakers of utilization B having a rated short-time withstand current equal to their rated ultimate short-circuit breaking capacity, this test sequence need not be made, since, in this case, the ultimate short-circuit breaking capacity, is verified when carrying out test sequence IV.		
	For integrally fused circuit-breakers, test sequence V applies in place of this sequence.		
	Type designation or serial number	TS1600H/3P	
	Sample no:	S3-3	
	Rated current: In (A)	1600 A	
	Rated operational voltage: Ue (V)	460 V	
	Rated ultimate short-circuit breaking capacity: (kA)	65 kA	
	Rated control supply voltage of closing mechanism: Uc (V)		
	Rated control supply voltage of shunt release: Uc (V)		

ВЕРНО С
ОРИГИНАЛА

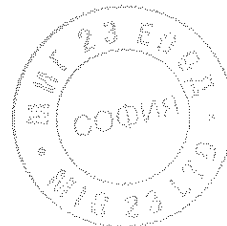

IEC 60947-2			
Clause	Requirement + Test	Result - Remark	Verdict
	This test sequence need not be made when Icu = Ics		
8.3.5.1	The operation of overload releases shall be verified at twice the value of their current setting on each pole separately.		
	The operating time shall not exceed the max. value stated by the manufacturer for twice the current setting at the reference temperature, on a pole singly.		
	Time specified by the manufacturer:	152~317 s	P
	- Operation time: (s) L1:	211 s	P
 L2:	215 s	
 L3:	209 s	
 N :		
8.3.5.2	Test of rated ultimate short-circuit breaking capacity		
	The test sequence of operations is O – t – CO		
	For circuit-breaker fitted with adjustable releases, test shall be made with the current and time settings at maximum.	Compliance	P
	closing mechanism energized with 85% at the rated Uc: (V)	-	N/A
	The circuit-breaker is mounted complete on its own support or an equivalent support.	Compliance	P
	Test made in free air:	Compliance	P
	Distances of the metallic screen's: (all sides)	Side : 73.5 mm, Front : 0 mm Top bottom : no screen	P
	The characteristics of the metallic screen:		
	- woven wire mesh	-	N/A
	- perforated metal	Compliance	P
	- expanded metal	-	N/A
	- ratio hole area/total area: 0,45-0,65	0,5	P
	- size of hole: <30mm ²	< 30mm ²	P
	- finish: bare or conductive plating	Compliance	P
	Test made in specified individual enclosure: Details of these tests, including the dimensions of the enclosure:	-	N/A
	Fuse "F": copper wire: diameter 0,8 mm, 50 mm long	Compliance	P
	Circuit is earthed at: (load-star- or supply-star point)	Load-star point	P
	Conductor cross-sectional area (mm ²) :	2CX50X10 mm ²	P

TRF No. IEC60947_2F

ВЕРНО С
ОРИГИНАЛА

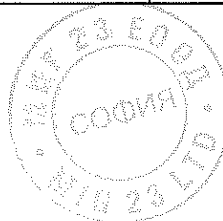

IEC 60947-2			
Clause	Requirement + Test	Result - Remark	Verdict
	If terminals unmarked: line connected at: (underside/upside)	-	N/A
	Tightening, torques: (Nm)	50 Nm	P
	Test sequence of operation: O – t – CO	Compliance	P
	- test voltage U/Ue = 1,05 (V) L1: L2: L3:	L1: 484,6 V L2: 485,5 V L3: 484,4 V	P
	- r.m.s. test current AC/DC: (A)..... L1: L2: L3:	L1: 67,0 kA L2: 65,7 kA L3: 65,8 kA	P
	power factor/time constant :	0,20	P
	- Factor "n"	2,25	P
	- peak test current (Amax) :	149,3 kA	P
	Test sequence "O"		
	- max. let-through current: (kApeak) L1: L2: L3:	L1: 140,3 kA L2: 111,6 kA L3: 105,7 kA	P
	- Joule integral I ² dt (A ² s) L1: L2: L3:	L1: 98,9 MA ² s L2: 65,2 MA ² s L3: 50,2 MA ² s	P
	Pause, t: (min)	5	P
	Test sequence "CO"		
	- max. let-through current: (kApeak) L1: L2: L3:	L1: 98,7 kA L2: 130,0 kA L3: 125,9 kA	P
	- Joule integral I ² dt (A ² s) L1: L2: L3:	L1: 58,9 MA ² s L2: 93,2 MA ² s L3: 93,3 MA ² s	P
	Melting of the fusible element	Compliance	P
	Holes in the PE-sheet for test sequence "O"	-	N/A
	Cracks observed	Compliance	P
8.3.5.3	Verification of dielectric withstand		
	- equal to twice the rated operational voltage with a minimum of 1000 V for 5 seconds	1000 V	P
	- no breakdown or flashover	No	P

TRF No. IEC60947_2F

ВЯРНО С
ОРИГИНАЛА

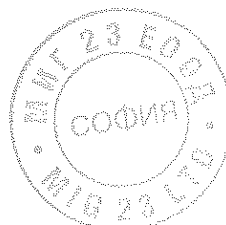

IEC 60947-2			
Clause	Requirement + Test	Result - Remark	Verdict
	- the leaking current for circuit-breaker suitable for isolation: (<6mA / 1,1 Ue)	≤ 3,0 mA / 506 V	P
8.3.5.4	Verification of overload releases		
	The operation of overload releases shall be verified at 2,5 times the value of their current setting on each pole separately.		
	The operating time shall not exceed the max. value stated by the manufacturer for twice the current setting at the reference temperature, on a pole singly.		
	Time specified by the manufacturer:	92~182 s	P
	- Operation time: (s) L1: L2: L3: N :	127 s 128 s 127 s	P

8.3.5	TEST SEQUENCE III (Icu)		
	Rated ultimate short-circuit breaking		
	Except where the combined test sequence applies, this test sequence applies to circuit-breaker of utilization category A and to circuit-breaker of utilization B having a rated ultimate short-circuit breaking capacity higher than the rated short-time withstand current.		
	For circuit-breakers of utilization B having a rated short-time withstand current equal to their rated ultimate short-circuit breaking capacity, this test sequence need not be made, since, in this case, the ultimate short-circuit breaking capacity, is verified when carrying out test sequence IV.		
	For integrally fused circuit-breakers, test sequence V applies in place of this sequence.		
	Type designation or serial number	TS1600H 3P	
	Sample no:	S3-4Rev	
	Rated current: In (A)	1600 A	
	Rated operational voltage: Ue (V)	690 V	
	Rated ultimate short-circuit-breaking capacity: (kA)	45 kA	
	Rated control supply voltage of closing mechanism: Uc (V)		
	Rated control supply voltage of shunt release: Uc (V)		

ВЯРНО С
ОРИГИНАЛА

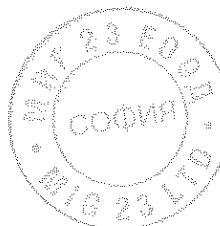

IEC 60947-2			
Clause	Requirement + Test	Result - Remark	Verdict
	This test sequence need not be made when Icu = Ics		
8.3.5.1	The operation of overload releases shall be verified at twice the value of their current setting on each pole separately.		
	The operating time shall not exceed the max. value stated by the manufacturer for twice the current setting at the reference temperature, on a pole singly.		
	Time specified by the manufacturer:	152~317 s	P
	- Operation time: (s) L1:	214 s	P
 L2:	203 s	
 L3:	211 s	
 N :		
8.3.5.2	Test of rated ultimate short-circuit breaking capacity		
	The test sequence of operations is O – t – CO		
	For circuit-breaker fitted with adjustable releases, test shall be made with the current and time settings at maximum.	Compliance	P
	closing mechanism energized with 85% at the rated Uc: (V)	-	N/A
	The circuit-breaker is mounted complete on its own support or an equivalent support.	Compliance	P
	Test made in free air:	Compliance	P
	Distances of the metallic screen's: (all sides)	Side : 73.5 mm, Front : 0 mm Top bottom : no screen	P
	The characteristics of the metallic screen:		
	- woven wire mesh	-	N/A
	- perforated metal	Compliance	P
	- expanded metal	-	N/A
	- ratio hole area/total area: 0,45-0,65	0,5	P
	- size of hole: <30mm ²	< 30mm ²	P
	- finish: bare or conductive plating	Compliance	P
	Test made in specified individual enclosure: Details of these tests, including the dimensions of the enclosure:	-	N/A
	Fuse "F": copper wire: diameter 0,8 mm, 50 mm long	Compliance	P
	Circuit is earthed at: (load-star- or supply-star point)	Load-star point	P
	Conductor cross-sectional area (mm ²) :	2CX50X10 mm ²	P

TRF No. IEC60947_2F

ВЕРНО С
ОРИГИНАЛА

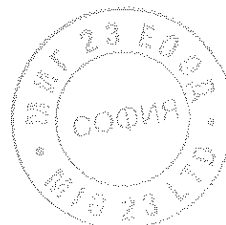

IEC 60947-2			
Clause	Requirement + Test	Result - Remark	Verdict
	If terminals unmarked: line connected at: (underside/upside)	-	N/A
	Tightening, torques: (Nm)	50 Nm	P
	Test sequence of operation: O – t – CO	Compliance	P
	- test voltage U/Ue = 1,05 (V) L1: L2: L3:	L1: 734,8 V L2: 734,8 V L3: 733,0 V	P
	- r.m.s. test current AC/DC: (A)..... L1: L2: L3:	L1: 45,3 kA L2: 45,0 kA L3: 45,3 kA	P
	power factor/time constant :	0,24	P
	- Factor "n"	2,13	P
	- peak test current (Amax) :	96,6 kA	P
	Test sequence "O"		
	- max. let-through current: (kApeak) L1: L2: L3:	L1: 95,8 kA L2: 74,1 kA L3: 79,1 kA	P
	- Joule integral I ² dt (A ² s) L1: L2: L3:	L1: 52,1 MA ² s L2: 33,8 MA ² s L3: 32,0 MA ² s	P
	Pause, t: (min)	10	P
	Test sequence "CO"		
	- max. let-through current: (kApeak) L1: L2: L3:	L1: 94,3 kA L2: 86,4 kA L3: 69,1 kA	P
	- Joule integral I ² dt (A ² s) L1: L2: L3:	L1: 48,9 MA ² s L2: 43,5 MA ² s L3: 28,0 MA ² s	P
	Melting of the fusible element	Compliance	P
	Holes in the PE-sheet for test sequence "O"	-	N/A
	Cracks observed	Compliance	P
8.3.5.3	Verification of dielectric withstand		
	- equal to twice the rated operational voltage with a minimum of 1000 V for 5 seconds	1 380 V	P
	- no breakdown or flashover	No	P

TRF No. IEC60947_2F

 ВЪРНО С
ОРИГИНАЛА
